



INSTALLATION, SERVICE AND MAINTENANCE INSTRUCTIONS

MAGNETIC AGITATOR BMA



INOXPA, S.A.U.

Telers, 60 Apto. 174
17820 - Banyoles

Tel.: +34 972 57 52 00

Fax: +34 972 57 55 02

inoxpa@inoxpa.com

www.inoxpa.com

Original Manual

20.055.30.00EN

(0) 2018/03

1. Index

1. Index	2
2. Guarantee and Exclusions	3
2.1. Guarantee	3
2.2. Exclusions of liabilityEXCLUSIONS OF LIABILITY	3
3. General Information	4
3.1. Safety instructions	4
3.2. Manufacturer and country of origin	5
3.3.  Compliance.....	5
3.4. Data tag	6
3.5. Description and operation of the INOXPA magnetic drive system	6
4. Transport, Storage and Installation	7
4.1. Packaging and Storage.....	7
4.2. Preliminary assembly operations	7
4.3. Assembly and installation	7
4.4. Shroud installation guide for agitator BMA	8
4.5. Bushing mounting instruction.....	10
4.6. Pivot mounting instruction	11
4.7. Note for installation.....	12
5. Start-up	14
5.1. Start-up instructions.....	14
5.2. Troubleshooting	17
6. Maintenance	18
6.1. Agitator's components – Outside the tank.....	18
6.2. Agitator's components – Inside the tank.....	18
7. Miscellaneous	19
7.1. Tightening torques.....	19
7.2. Overhaul	19
7.3. Spare parts.....	19
7.4. Recommendations	19
8. Disassembly and removal	20
8.1. Dismantling sequence	20
8.2. Draining	20

2. Guarantee and Exclusions

2.1. GUARANTEE

The products here described (excluded the parts subject to wear) are guaranteed from the company INOXPA for two years, beginning from the supply's date from manufacturing store.
The present guarantee covers material and manufacturing defects.

2.2. EXCLUSIONS OF LIABILITY

Transport damages are excluded.
The company INOXPA, assumes no liability for damages caused by improper handling and use.
Indirect damages are excluded from liability.

3. General Information

3.1. SAFETY INSTRUCTIONS

	<p>SAFETY INSTRUCTIONS</p> <ul style="list-style-type: none"> • The requirements provided in correspondence of this symbol, marked on green background with a border, are exclusive reference to equipment which complies with Directive 2014/34/EU (products intended for use in areas at risk of explosion). • The manual drawn up for the ATEX Directive is an integral part in the instruction manual and maintenance.
-----------------------------------------------------------------------------------	-----------------------------------------------------------------------------------------------------------------------------------------------------------------------------------------------------------------------------------------------------------------------------------------------------------------------------------------------------------------------------------------------------------------------------------------------------------

The operations of installation, connection, start-up, maintenance and repair can be performed only by qualified personnel, which should take into consideration the following:

- these specific instructions, along with any other instruction for the equipment or system installed;
- the warning signals and information on the equipment;
- regulations and specific requirements for the plant where the mixer work (national and regional regulations in force).

	<p>SAFETY INSTRUCTIONS</p> <ul style="list-style-type: none"> • For an use in conformity with the ATEX Directive 2014/34/EU, respect the technical data indicated on the tag plate and documentation that must be placed in the proximity of the unit. • The agitator is for an environment with danger of explosion because of the presence of gas-air mixtures and dust-air. • The equipment group II, category 1/2 can be used in areas 0, 20 process side and areas 1, 21, 2, 22 outer side. • The equipment group II, category 2 can be used exclusively in areas 1, 21, 2, 22. • The equipment group II, category 3 can be used exclusively in areas 2, 22 • Use the mixer in combination with other equipment only if they can operate at least in same areas. The characteristics of explosive mixture must respect the maximum temperature data reported in marking. • In case of using the mixer in a potential explosive atmosphere due to dust-air mixture, the minimum booster temperature for the cloud of dust must be higher than the value stated on the tag plate, multiplied by a coefficient of 1,5, to which must be added 75°K if it is assumed a deposition of layers of dust less than 5 mm.
-------------------------------------------------------------------------------------	--------------------------------------------------------------------------------------------------------------------------------------------------------------------------------------------------------------------------------------------------------------------------------------------------------------------------------------------------------------------------------------------------------------------------------------------------------------------------------------------------------------------------------------------------------------------------------------------------------------------------------------------------------------------------------------------------------------------------------------------------------------------------------------------------------------------------------------------------------------------------------------------------------------------------------------------------------------------------------------------------------------------------------------------------------------------------------------------------------------------------------------------------------------------------------------------------------------------------------------------------------------------------------------------------

	<p>CAUTION!!</p> <ul style="list-style-type: none"> • The procedures for transport, storage, maintenance, putting into operation, etc.,. Must be carried out by qualified personnel in the absence of explosive atmosphere and the electricity should be strictly off, putting in out of service, taking precautions to any condition that might restart the system
-------------------------------------------------------------------------------------	-------------------------------------------------------------------------------------------------------------------------------------------------------------------------------------------------------------------------------------------------------------------------------------------------------------------------------------------------------------------------------------------

	<p>CAUTION!!</p> <ul style="list-style-type: none"> • INOXPA will be responsible only for a materials and equipment provided, selected on the basis of data on the conditions of operation, the information provided by the customer or by the end user, indicated in the order confirmation.
-------------------------------------------------------------------------------------	---------------------------------------------------------------------------------------------------------------------------------------------------------------------------------------------------------------------------------------------------------------------------------------------------------------------

	<p>SAFETY INSTRUCTIONS</p> <ul style="list-style-type: none"> • All other equipment assembled should have a separate certification of a grade of protection higher or at least equal to the mixer one.
-------------------------------------------------------------------------------------	------------------------------------------------------------------------------------------------------------------------------------------------------------------------------------------------------------------------------

	<p>CAUTION!!</p> <ul style="list-style-type: none"> • The entire unit must be certified separately by the manufacturer and must have a separate name plate
-------------------------------------------------------------------------------------	----------------------------------------------------------------------------------------------------------------------------------------------------------------------------------

	<p>CAUTION!!</p> <ul style="list-style-type: none"> For further information the customer is requested to contact the technical office of the manufacturer to verify the compatibility of application.
-----------------------------------------------------------------------------------	-----------------------------------------------------------------------------------------------------------------------------------------------------------------------------------------------------------------------------

	<p>CAUTION!!</p> <ul style="list-style-type: none"> The inner and outer rotors are fitted with Permanent Magnets creating a strong magnetic field. The mishandling of rotors (such as storage in a dirty place exposed to ferritic powders) may be detrimental to their own efficiency.
-----------------------------------------------------------------------------------	---------------------------------------------------------------------------------------------------------------------------------------------------------------------------------------------------------------------------------------------------------------------------------------------------------------

	<p>CAUTION!!</p> <ul style="list-style-type: none"> Keep away from magnets all objects featuring magnetic bands, such as credit cards, floppy disks, etc.
-----------------------------------------------------------------------------------	---------------------------------------------------------------------------------------------------------------------------------------------------------------------------------

	<p>VERY DANGEROUS</p> <ul style="list-style-type: none"> Users of pacemakers must not get close to magnets because the magnetic field may cause malfunctions to these devices, with consequent serious risks to people's health.
-----------------------------------------------------------------------------------	--------------------------------------------------------------------------------------------------------------------------------------------------------------------------------------------------------------------------------------------------------

	<p>SAFETY INSTRUCTIONS</p> <ul style="list-style-type: none"> The agitator is not intended for mixing powders in the absence of liquid or in the absence of a quantity of liquid strongly predominant.
-----------------------------------------------------------------------------------	------------------------------------------------------------------------------------------------------------------------------------------------------------------------------------------------------------------------------

3.2. MANUFACTURER AND COUNTRY OF ORIGIN

INOXPA S.A.U.
 Telers, 60
 17820 Banyoles
 Spain

3.3. COMPLIANCE



The directives applicable to the agitators are:

- Machine Directive 2006/42/CE
- EMC Directive 2014/30/EU
- Low Voltage Directive 2014/35/EU

	<p>ATEX VERSIONS</p> <ul style="list-style-type: none"> Directive ATEX 2014/34/EU <p>Uniformed apply norms:</p> <ul style="list-style-type: none"> UNI EN 1127-1 Explosive atmosphere UNI EN 13463-1 Non-electrical equipment for potential and explosive atmosphere – Part 1 UNI EN 13463-5 Non-electrical equipment for potential and explosive atmosphere – Part 5 CEI CLC/TR 50404 Guide and recommendations in order to avoid dangers due to static electricity ATEX GUIDELINE 4° EDITION - 2012
-------------------------------------------------------------------------------------	---------------------------------------------------------------------------------------------------------------------------------------------------------------------------------------------------------------------------------------------------------------------------------------------------------------------------------------------------------------------------------------------------------------------------------------------------------------------------------------------------------------------------------------------------------------------------------------

3.4. DATA TAG

The product is identified by a name plate fixed in a clearly and indelible way to the equipment.

	
INOXPA S.A.U. C. TELERS, 60 - 17820 BANYOLES GIRONA (SPAIN) . www.inoxpa.com	
Type <input type="text"/>	
No <input type="text"/>	Year <input type="text"/>
<input type="text"/>	



II 2 GD c IIB T4

CE ATEX mark affixed to the manufacturer's plate

3.5. DESCRIPTION AND OPERATION OF THE INOXPA MAGNETIC DRIVE SYSTEM

SCHEMA MSB / MSB SCHEME

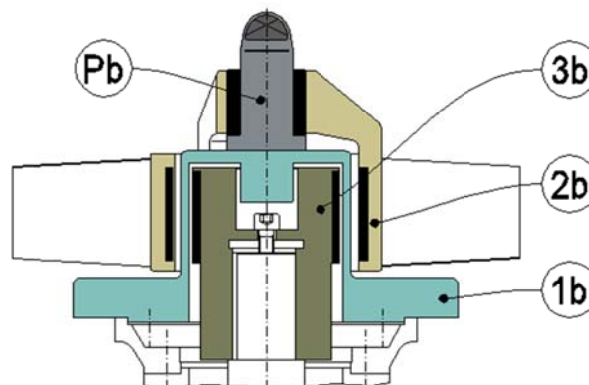

The magnetic drive system is composed of:

- 1b** – Hermetical-seal shroud to be welded to the vessel
- 2b** – Inner rotor fitted with fully encapsulated permanent magnets that cause the mixing by the blades on the rotor itself (impeller).
- 3b** – Outer rotor fitted with permanent magnets (connected to the driving unit); the motion is transmitted to the inner rotor by the magnetic field.

4. Transport, Storage and Installation

4.1. PACKAGING AND STORAGE

Store the agitator in a dry and clean environment, and do not remove packaging until installation. Protect the packaging from any kind of impact to avoid damages to any component. Upon delivery of the shipment, make sure that it is in perfect conditions and no damages have occurred during transportation. If necessary, contact the forwarding agent or the supplier in order to agree on the steps to be followed in case of damages.

4.2. PRELIMINARY ASSEMBLY OPERATIONS

Check on site for the consistency of the installation dimensions that are needed for the agitator's coupling flange (see drawing view).

Before handling the agitator, read section **3.1 Safety instructions**

During handling and transportation towards the installation area, pay special attention to the choice of hooking points for hoisting the unit;

Any slight deformation or impact may change the alignment of the rotor, with consequent increased vibrations during the operation

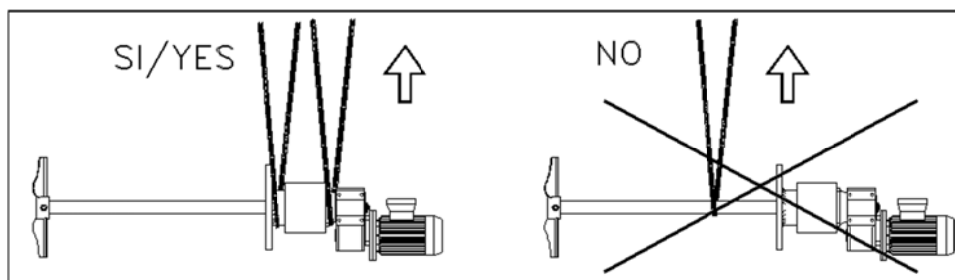

4.3. ASSEMBLY AND INSTALLATION

CAUTION!! See actions **3.1 Safety instructions**

- Weld the shroud "**1b**" as described in the chapter 4.4. Shroud installation guide for agitator BMA

	<p>CAUTION!!</p> <ul style="list-style-type: none"> Assembly must be carried out with the utmost care and attention by qualified staff, which shall check through scheme page 9, in compliance with the following instructions, to avoid possible damages
-------------------------------------------------------------------------------------	---------------------------------------------------------------------------------------------------------------------------------------------------------------------------------------------------------------------------------------------------------------------------------

	<p>CAUTION!!</p> <ul style="list-style-type: none"> IT IS ABSOLUTELY NECESSARY TO INSTALL THE IMPELLER (INNER ROTOR) "2b" BEFORE PLACING THE OUTER ROTOR "3b", FIXED ON THE MOTORIZATION GROUP, IN ORDER TO AVOID THE BREAKAGE OF THE GUIDE PIVOT "Pb" AND THE IMPELLER BUSHING "2b".
-------------------------------------------------------------------------------------	-----------------------------------------------------------------------------------------------------------------------------------------------------------------------------------------------------------------------------------------------------------------------------------------------------------------------------------------

- Install to the guide pivot "**Pb**", as stated in the chapters 4.5. and 4.6.
- Gently insert inside the tank, the impeller (inner rotor) "**2b**", the guide pin "**Pb**", previously installed on the shroud "**1b**".
- Assemble the motorization group with the utmost care, pay attention not to hit the outer rotor "**3b**", fixed to the motorization group, with a foreign body.

	<p>WARNING!!</p> <ul style="list-style-type: none"> • DO NOT CARRY THE TANK WITH THE MIXER INSTALLED • MIXER INSTALLATION MUST BE DONE IN PLACE
--	---------------------------------------------------------------------------------------------------------------------------------------------------------------------------------------

4.4. SHROUD INSTALLATION GUIDE FOR AGITATOR BMA

4.4.1. Orientation of the shroud

The orientation of the mixer foresees that the shrouds with diameter less than 119 mm have threaded holes on the center axle of the motor.

On the contrary shrouds with diameter more than 119 mm, have threaded holes positioned at 45° on the motor center axle, except that differently specified on the drawing.

Figure 1 shows the bottom of the vessel seen from above (inside)

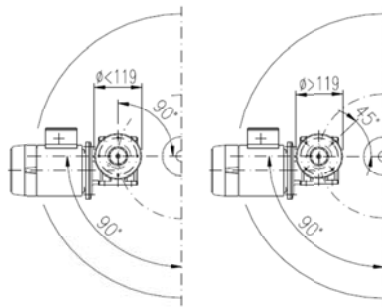

Fig. 1

4.4.2. Positioning of the shroud

4.4.2.1. FREE DISTANCE BETWEEN WELDS

Before position the shroud check that the minimum distance (WD) between the shroud welds and any other weld correspond to the vessel technical specifications.

Calculation to be used in order to find the correct positioning of the shroud in the vessel	Vessel diameter D_e	Distance D
	< 1000 mm	0,5 x LR
	> 1000 mm	0,3 – 0,5 x LR

This table is to be considered valid only if not in contrast with point 4.4.2.1.

4.4.2.2. DIRECTION

The shroud must be welded flush with the inner surface of the vessel. Its axle shall be perpendicular to the bottom of the vessel crossing the vessel axle, fig. 2

4.4.2.3. MAKING THE HOLE FOR THE SHROUD

Before making the hole in the vessel make sure that all the welds on the vessel are completed, for example outlet valves, connections for sensors, etc.

Holding into consideration the recommendations of par 4.4.2.1 and 4.4.2.2, make the hole in the vessel, that shall be of the same diameter of the shroud, avoiding to leave any air gap between the shroud and the edge of the hole. The inner edge of the vessel must be round in order to make a 45° angle sloping inwards (creating a weld groove). On the outer edge of the hole must be left a straight part of approx. 2 mm, fig. 3

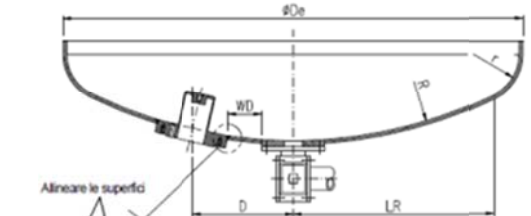

Fig. 3

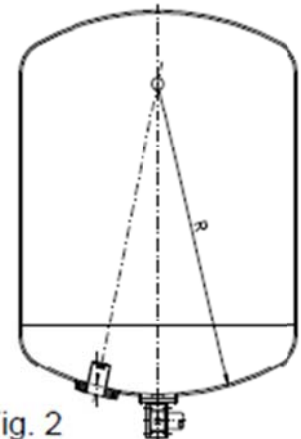

Fig. 2

4.4.3. Welding instructions

The intent of the following instructions is to avoid deformation of the shroud due to weld phase.

4.4.3.1. BEFORE WELDING

Make sure that the shroud pivot is removed. Using a welding method that is not in contrast with the vessel technical specifications.

4.4.3.2. POSITIONING AND WELDING OF THE SHROUD (OUTSIDE VESSEL)

After have cleaned the working surfaces:

- ◆ Place the shroud into the vessel hole checking that the inner surface of the vessel is flush with the outer edges of the shroud, see fig. 3
- ◆ Check the alignment of the shroud holes as described in chapter 4.4.1. and fig. 4
- ◆ Tack weld externally of the vessel at A and B, check the alignment and inclination, make necessary corrections (fig. 4)

Tack weld at C and D (fig. 4)

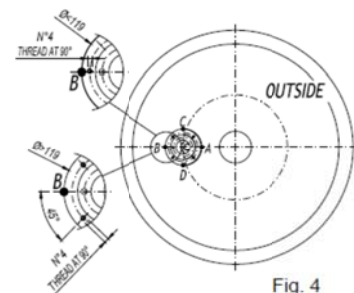

Fig. 4

4.4.3.3. WELDING OF THE SHROUD (INSIDE VESSEL)

After have cleaned the working surfaces tack weld the shroud following the numbers as indicated in fig. 5 avoiding to overheat it in excess.

4.4.3.4. FINAL WELDING (INSIDE VESSEL)

Using filler material, weld the shroud following the instructions as indicated below and see also fig. 6. The procedure is continued until the weld groove is filled according to the vessel technical specifications.

- ◆ First phase:
 - Weld the section “a-b” blow cool with compressed air
 - Weld the section “d-e” blow cool with compressed air
 - Weld the section “g-h” blow cool with compressed air
 - Quench with water and dry well
- ◆ Second phase:
 - Weld the section “b-c” blow cool with compressed air
 - Weld the section “e-f” blow cool with compressed air
 - Weld the section “h-i” blow cool with compressed air
 - Quench with water and dry well
- ◆ Third phase:
 - Weld the section “c-d” blow cool with compressed air
 - Weld the section “f-g” blow cool with compressed air
 - Weld the section “i-a” blow cool with compressed air
 - Quench with water and dry well

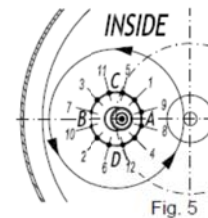

Fig. 5

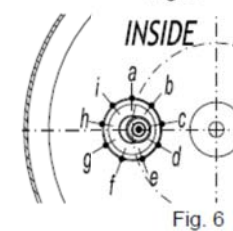

Fig. 6

Attention: do not overheat the shroud, there is risk of deformation.

4.4.3.5. FINAL WELDING (OUTSIDE VESSEL)

Use the same procedure of the inner vessel above mentioned.

4.4.4. Grinding / Polishing

After cooling, the welds can be round and polished according to the vessel technical specifications.

All the mentioned operations must respect the following conditions:

- The welder must be authorized and qualified for these kind of welding operations.
- It is important that the applied heat is well balanced and evenly spread along the weld seam, in order to obtain a weld without imperfections.

4.5. BUSHING MOUNTING INSTRUCTION

1. Clean the O-ring (pos. 6) and pivot (pos. 4) seat on the shroud before the installation.
2. Clean the floor for the bushing (pos. 5) on the shroud before the installation.
3. Put the O-ring (pos. 6) in its own seat.
4. Place the bushing (pos. 5) on the shroud checking that the hole (F) coincide with the steady pin (S).
5. Block the bushing (pos. 5) screwing the pivot (pos. 4), having already placed the O-ring (pos. 7) on the pivot.
6. Tighten the pivot (pos. 4) with maximum torque 22 Nm.
7. Place the impeller (pos. 2) on the bushing.

ATTENTION: Before the start up, check that the sense of rotation of the mixer is the same as shown in the scheme by the arrow.

ATTENTION: Do not damage the inside rotor, the impeller and the shroud, while removing from original seat.

ATTENTION: The installation of impeller (pos. 2) must be done in place.

DO NOT TRANSPORT the tank with the impeller installed.

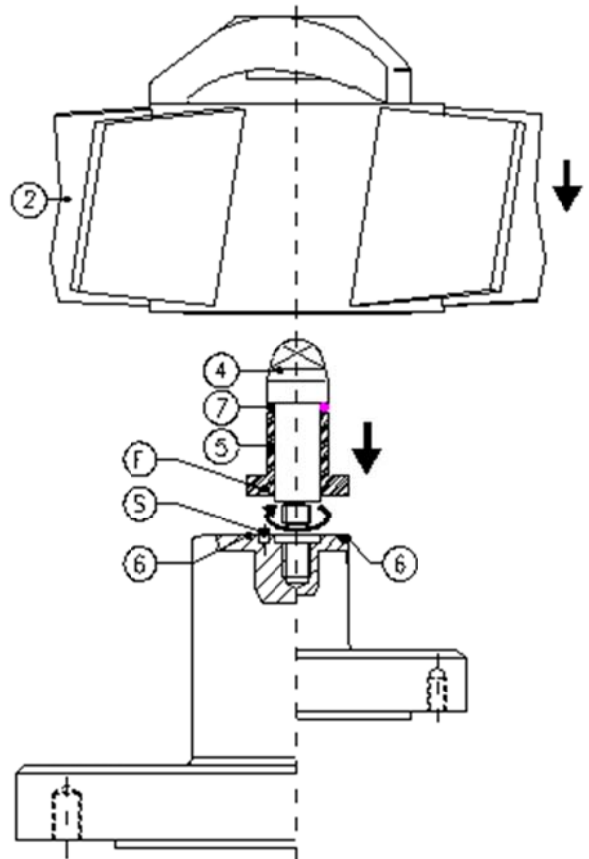

4.6. PIVOT MOUNTING INSTRUCTION

4.6.1. For BMA-100, BMA-125 AND BMA-150

1. Clean the floor for the pivot (pos. 4) on the shroud before the installation.
2. Leave the O-ring (pos. 7) in its own seat if present.
3. Before placing the pivot on the shroud, remove the steady pin (S) if present.
4. Screw the pivot (pos. 4), with the O-ring (pos. 7), already placed on the shroud.
5. Tighten the pivot (pos. 4) with maximum torque 22 Nm.
6. Place the impeller (pos. 2) on the pivot (pos. 4)

ATTENTION: Before the start up, check that the sense of rotation of the mixer is the same as shown in the scheme by the arrow.

ATTENTION: Do not damage the inside rotor, the impeller and the shroud, while removing from original seat.

ATTENTION: The installation of impeller (pos. 2) must be done in place.

DO NOT TRANSPORT the tank with the impeller installed.

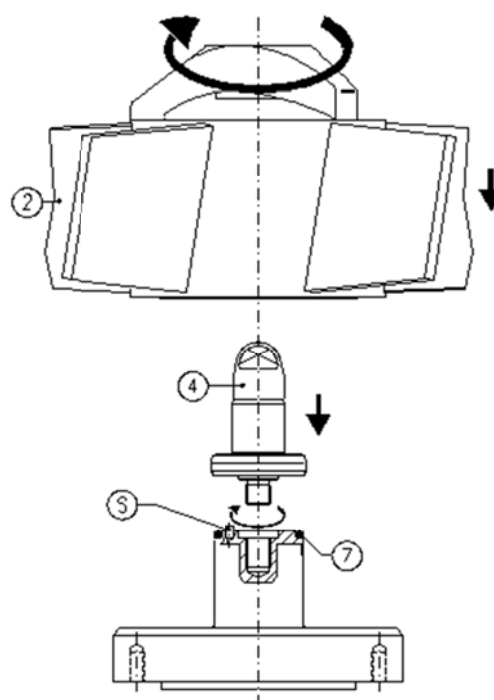

4.6.3. For other models

1. Clean the O-ring (pos. 6) seat on the pivot (pos. 4).
2. Clean the floor for the pivot (pos. 4) on the shroud before the installation.
3. Leave the O-ring (pos. 7) in its own seat if present.
4. Before placing the pivot on the shroud, remove the steady pin (S) if present.
5. Screw the pivot (pos. 4) with the O-ring (pos. 6).
6. Screw the pivot (pos. 4) with maximum torque 22 Nm.
7. Place the impeller (pos. 2) on the pivot (pos. 4).

ATTENTION: Before the start up, check that the sense of rotation of the mixer is the same as shown in the scheme by the arrow.

ATTENTION: Do not damage the inside rotor, the impeller and the shroud, while removing from original seat.

ATTENTION: The installation of impeller (pos. 2) must be done in place.

DO NOT TRANSPORT the tank with the impeller installed.

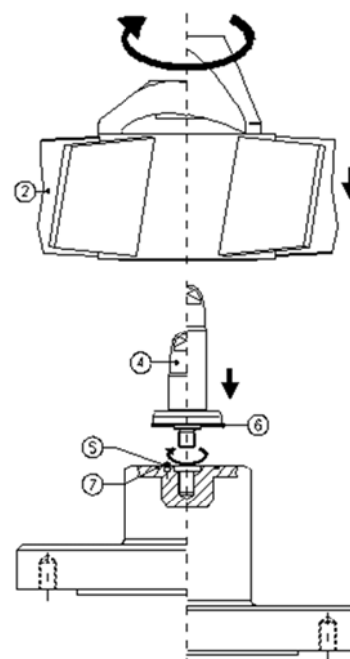

4.7. NOTE FOR INSTALLATION

	<p>INSTALLATION</p> <ul style="list-style-type: none"> • The installation procedures must take place in absence of explosive atmosphere • The atmosphere of use must comply with the directions of maximum surface temperature stated in the name plate according to ATEX directive • Arrange appropriate protections to prevent dangerous accumulations of dust/liquid close to mechanical seals and shafts. • Plan appropriate procedures for regular cleaning to prevent the formation of dangerous accumulations of dust in the proximity of mechanical seals and shafts • For a proper use in an explosive atmosphere along with other devices (such as an electric motor) be sure that it complies with ATEX directive at least the same category of the mixer (see name plate). • Components and equipment accessories, such motor, mechanical seal, gearbox, etc. must be used according to the instruction manuals, provided with mixer documentation. • Make sure that the load applied does not exceed the values for which the agitator is intended
-----------------------------------------------------------------------------------	---------------------------------------------------------------------------------------------------------------------------------------------------------------------------------------------------------------------------------------------------------------------------------------------------------------------------------------------------------------------------------------------------------------------------------------------------------------------------------------------------------------------------------------------------------------------------------------------------------------------------------------------------------------------------------------------------------------------------------------------------------------------------------------------------------------------------------------------------------------------------------------------------------------------------------------------------------------------------------------------------------------------------------------------------------------------------------------------------------------------------------------------

- ◆ Prior to installation, please verify whether the equipment and materials are compatible with the process fluid and with the operating environment where they will be installed.
- ◆ Check the availability in space for assembly.
- ◆ The equipment may produce vibrations while operating: during installation, please verify that the above vibrations do not resonate within the structure upon which the equipment is installed, and check that vibrations do not cause damages to the surrounding environment.
- ◆ The system's connection cables must not transfer any strain and/or vibration to the equipment
- ◆ Verify that the size of the support structure (beams, plates, flanges, etc.) is suitable to the equipment's weight, also considering the static and dynamic loads produced by the agitator.
- ◆ Anchor bolts must be suitable to anchor holes (do not use screw of a smaller size) and must be fitted with flat washers and spring washers.
- ◆ Verify that cylindrical tanks feature vortex breakers (if requested).
- ◆ Make sure that you can insert impellers (whether disassembled or installed on the shaft) in the bin through the specially provided ports, without forcing them.
- ◆ In case of outdoor installation, at least the motor must be sheltered by a roof.
- ◆ The unit composed by motor, gearbox, variator and spider is normally a single unit that must be assembled onto the support structure keeping the tightening torque values provided (see table on section 7.1 Tightening torques). Special attention must be paid to the flatness of surfaces, in order to guarantee a correct shaft rotation free from oscillations that may compromise mechanical stability.
- ◆ Verify that impellers are assembled in compliance with the correct direction of rotation and make sure that they are safely fixed onto the shaft; if dowels are used for fastening purposes, find the right position of the impeller and then carve some "slots" on the shaft (if the shaft is not factory slotted) on the areas corresponding to the dowel position.
- ◆ In case of the installation of two impellers or more, check for the right spacing between each other along the shaft.
- ◆ The shaft must not bend while inserting it into the bin, and must be positioned in such a way as not to bear the weight of the motor unit.
- ◆ In case the shaft and/or impellers are made of several flanged parts, perform the coupling according to the factory marks provided on the parts and tighten coupling bolts according to the tightening torques provided on the table of section 7.1 Tightening torques
- ◆ Excessively cold temperatures, ice or snow may cause problems to the process fluid or to the equipment, with possible cavitation and permanent deformation of the equipment and damages to seals. Therefore the operating conditions of the equipment must always be observed.
- ◆ Suitable protection from atmospheric agents must be provided. Rain, moisture, etc. do not affect equipment operation, but may reduce its life in the long run.
- ◆ Finally, proceed to the assembly of all accessory parts (if supplied separately), such as:
 - ◆ Bushing for bottom drains.
 - ◆ Nut caps for coated flanges of shafts/impellers.
 - ◆ Pressure gauge and thermometer for pressurization tanks.
 - ◆ Roof for motor protection.
 - ◆ Etc.
- ◆ Verify that the installation site is protected against thunderbolts and rambling electrical currents not directly attributable to the activity.

- ◆ Contact the technical department of:
INOXPA S.A.U. for installations flames and hot gasses

 A warning symbol consisting of a black exclamation mark inside a white triangle, which is itself inside a black square.	<p>ENVIRONMENTAL CONDITIONS!!</p> <p>The operation of equipment is allowed only with a temperature between 0°C and 40°C unless otherwise stated.</p>
-----------------------------------------------------------------------------------------------------------------------------------------------------------------------------------------------------------	-------------------------------------------------------------------------------------------------------------------------------------------------------------

5. Start-up

	<p>WARNING!! THESE KIND OF MIXERS MUST NOT RUN DRY EVEN IN THE INSPECTION STAGES, TESTING OR START-UP; IT IS THEREFORE NECESSARY THAT THE BUSHING/PIVOT ZONE IS SUBMERGED IN ORDER TO PERMIT A MINIMUM LUBRICATION.</p>
-----------------------------------------------------------------------------------	---------------------------------------------------------------------------------------------------------------------------------------------------------------------------------------------------------------------------------------------

5.1. START-UP INSTRUCTIONS

Prior to starting the agitator, it is strongly recommended to perform the following checks.

	<p>START-UP Before the start-up check:</p> <ul style="list-style-type: none"> • The ATEX compliance of each single accessory or apparatus connected to the mixer. • The compatibility of the atmosphere of the site where the mixer must work with the signs marking ATEX. • The maximum temperature of surfaces of the mixer shall not exceed the value indicated in tag plate. • Clean the mixer, once completed the full installation, making sure that there is accumulation of dust thickness is less than 5 mm <p>Fulfil carefully the procedures for regular cleaning to prevent the formation of layers of dangerous dust.</p>
-----------------------------------------------------------------------------------	------------------------------------------------------------------------------------------------------------------------------------------------------------------------------------------------------------------------------------------------------------------------------------------------------------------------------------------------------------------------------------------------------------------------------------------------------------------------------------------------------------------------------------------------------------------------------------------------------------------------------------------------------------------------------------------------------

	<p>CAUTION Before goodwill of agitator carry out a general check, being sure to have executed all the instructions set out in paragraph “4.3 Assembly and installation”.</p> <p>In particular check:</p> <ul style="list-style-type: none"> • That the mounting position of the mixer is correct • That the lubricant level of gearbox is correct and there are no leakages from the breather plugs or seals • That the voltage of the electric motor is in compliance with the system • That there no abnormal noises or vibrations <p>Stop immediately the mixer, in case of abnormal signs and contact immediately our technical department.</p>
-------------------------------------------------------------------------------------	--------------------------------------------------------------------------------------------------------------------------------------------------------------------------------------------------------------------------------------------------------------------------------------------------------------------------------------------------------------------------------------------------------------------------------------------------------------------------------------------------------------------------------------------------------------------------------------------------------------------------------------------------------------------------------------------------------------------------

◆ Motor:

The motors can be supplied pneumatic, hydraulic or electric.

For the electrical connection (single and three phases) fulfil the instructions of the motor tag plate and plaque linking terminals.

Install between the power lines and the motor and appropriate overload cut-out calibrated for the nominal current in amperes indicates on tag plate.

The cable inlet into the terminal block must be well insulated, and the cover must be screwed with care.

The motor ground clamp will be obligatory connected to the ground one.

The mixer should run in the direction indicated by the arrow.

	<p>WARNING!!</p> <ul style="list-style-type: none"> • Read entirely, the instruction manual related the motor, attached to the present manual, because the information contained in this paragraph are not complete with all issues related to a safe use of the motor itself.
-------------------------------------------------------------------------------------	------------------------------------------------------------------------------------------------------------------------------------------------------------------------------------------------------------------------------------------------------------------------------------------------------

TERMINAL BOARD'S WIRING DIAGRAMS

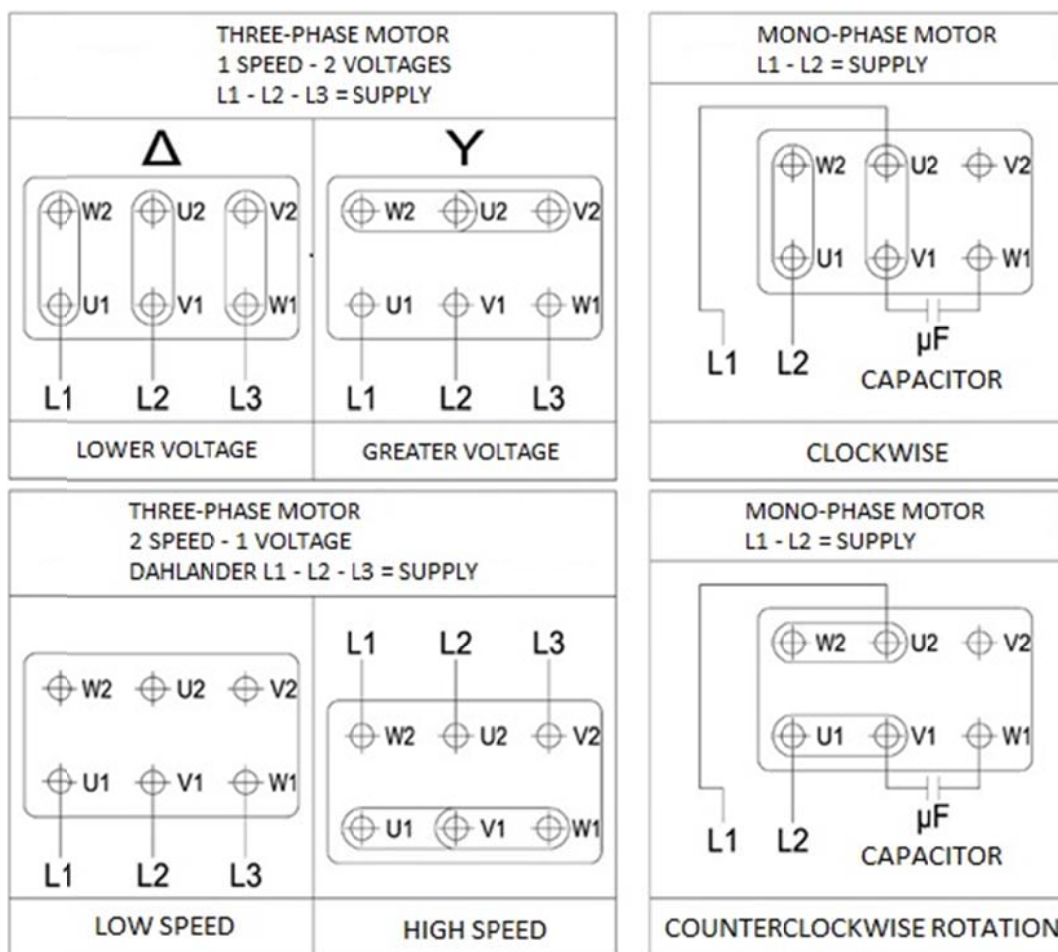

◆ Gearbox:

Check the oil level prior to operating the agitator.

Gearboxes may be lubricated as follows:

- Oil-less gearbox:

This type of gearboxes must be charged with the oil provided up to the max level indicated by a special mark.

Such gearboxes come with a warning tag with oil-charging instructions, and are fitted with a bleed plug.

- Oil-lubricated gearbox:

This type of gearboxes is fitted with non-drilled plugs; they come with warning tag and are fitted with a bleed plug.

For the above gearbox, the bleed cap must be fitted upon installation to replace the plug located on the highest position, in order to avoid overpressure in the casing during machine operation

Check the oil level with the frequency indicated by the manufacturer (attached manual)

- Gearbox supplied with oil grease "for life":

Gearboxes supplied with permanent lubrication systems with oil or grease "for life" are not fitted with charge plugs, level plugs and discharge plugs, and they are maintenance-free.

	<p>WARNING!!</p> <ul style="list-style-type: none"> • <i>Read entirely, the instruction manual related the gearbox, attached to the present manual, because the information contained in this paragraph are not complete with all issues related to a safe use of the gearbox itself.</i>
-------------------------------------------------------------------------------------	-----------------------------------------------------------------------------------------------------------------------------------------------------------------------------------------------------------------------------------------------------------------------------------------------------------------

◆ Variator:

Check the oli level prior to operating the agitator.

Variator are supplied with no oil inside. This type of gearboxes must be filled with the oil provided up to the max level indicated by a special mark.

Some types of variator are fitted with non-drilled plugs and are supplied with a bleed cap that must be fitted upon installation to replace the plug located on the highest position, in order to avoid overpressure caused by shaking and heating of oil during machine operation.

Speed variation is obtained by operating on the control handwheel of the variator.

Note: the control handwheel of the variator must not be operated when the speed controller is idle.

	<p>WARNING!!</p> <ul style="list-style-type: none">• Read entirely, the instruction manual related the variator, attached to the present manual, because the information contained in this paragraph are not complete with all issues related to a safe use of the variator itself.
-----------------------------------------------------------------------------------	----------------------------------------------------------------------------------------------------------------------------------------------------------------------------------------------------------------------------------------------------------------------------------------------------------

◆ **Seals:**

- **Lip seals (lip seal):**

No preliminary operation is needed for this type of seals, as they are ready for use immediately after installation onto the agitator's control unit.

- **Single mechanical seals:**

No preliminary operation is needed for this type of seals, as they are ready for use immediately after installation onto the agitator's control unit.

Verify whether the seal is suitable for rotating in either one or both directions of rotation.

Side agitators are fitted with seals that are located below fluid level. Make sure that seals are always covered with fluid; during discharge and refill operations, make sure that the tank is free from air bubbles in the seal area.

- **Double mechanical seals:**

They must be used with a coolant that must be circulating in the seal groove before the agitator is started. The fluid circulating between seals is normally kept at a pressure that is 1 atm above the bin pressure.

	<p>WARNING!!</p> <ul style="list-style-type: none">• REMOVE THE MECHANICAL SEAL BLOCKING SUPPORTS (IF ANY) BEFORE STARTING THE MIXER
-------------------------------------------------------------------------------------	------------------------------------------------------------------------------------------------------------------------------------------------------------------

	<p>WARNING!!</p> <ul style="list-style-type: none">• Read entirely, the instruction manual related the mechanical seal, attached to the present manual, and any specific annexes, because the information contained in this paragraph are not complete with all issues related to a safe use of the mechanical seal itself.
-------------------------------------------------------------------------------------	--------------------------------------------------------------------------------------------------------------------------------------------------------------------------------------------------------------------------------------------------------------------------------------------------------------------------------------------------

◆ **Pressure vessel (if equipped):**

It is important that the liquid of cooling of the mechanical seal is clean, not excessive viscous, of good thermal conductivity, with elevated point of boiling, compatible with the fluid in the tank.

Verify that all connection pipes are fitted and, if necessary, connect the pipes of the tank's cooling system.

If a pump is fitted for recycling the seals' coolant, makes sure that all electrical connections have been fitted.

	<p>WARNING</p> <p>Lubricants and / or refrigerants fluids of the equipment, must have a temperature of ignition (IEC 60079-4) at least 50° K more than the maximum temperature of the surface of the equipment in which they are included.</p>
-------------------------------------------------------------------------------------	-------------------------------------------------------------------------------------------------------------------------------------------------------------------------------------------------------------------------------------------------------

◆ **Impeller:**

Do not operate the agitator if the impeller is dipped in deposits at the bottom of the bin, unless the equipment has been designed to support such operating mode.

◆ **Complete unit:**

- Verify the tightening of all hardware (repeat the check after the first two weeks of machine operation).
- The mixer should run in the direction indicated by the arrow.
- Check the protection and control systems featured by the system.
- Make sure that the parts composing the full equipment are equipotential.

◆ **Magnetic drive system**

- The magnetic drive system does not require any maintenance.

Once the above checks have been performed, the agitator can be started from the specially designed control devices.

If gearboxes – variable speed are installed, is generally advisable:

- increase gradually the transmitted power, beginning from the minimum values.
 - alternatively, you can limit power (to 50-70% of maximum power) during the first operating hours.
- In the event of an unexpected excessive electrical input, insulate the motor from the supply mains, check for the perfect efficiency of the connection contacts and make sure that the recommended operating conditions are met, especially as fast as the fluid's density and viscosity are concerned. If the overload condition persists, please contact our technical assistance service.
- In case of vibrations, immediately stop the agitator and isolate the cause of vibrations.
- A strong vibration in variable speed mixers, operated by frequency converter or mechanical variator, could point out the proximity to a bending critical speed of the shaft.
- The mixer must immediately switch off and our technical office must be contacted, in order to verify the calculation of the critical speed.
- All agitators are suitable for operation under conditions of constant maximum level.
- Do not operate agitators in bins filled at a variable or low level, unless the equipment is specifically designed for this kind of operation.

5.2. TROUBLESHOOTING

A constant abnormal noise level indicates a possible malfunction. In this case, immediately stop the agitator and contact INOXPA.

If the system is left inoperative for extended periods, do not keep it under pressure.

Excessively high temperatures may damage the system.



Prior to detecting and defining a malfunction condition, it is first of all advised to check for any modification of the agitator's operating conditions.

During the warranty period the stirrer can be dismantled only with the presence of technicians INOXPA or by your technicians only after explicit request and subsequent confirmation and approval for intervention by INOXPA

- **If the motor gearbox is noisy:**
 - Check the oil level and change it, if necessary.
- **If the inner rotor vibrates**
 - Inspect the bushing and the pivot, and eventually replace them.
 - Check that no foreign particles are deposited on the impeller.
- **The motor gearbox does not start smoothly:**
 - Inspect the bushing and the pivot, and eventually replace them.
 - Check that no foreign particles are deposited on the impeller.
- **The heat protection system goes off repeatedly:**
 - Inspect the bushing and the pivot, and eventually replace them.
 - Check that no foreign particles are deposited on the impeller.
 - Check that the impeller is not stuck in the sediments.

6. Maintenance

CAUTION!! See section “3.1 Safety instructions”

	<p>PUTTING INTO SERVICE</p> <ul style="list-style-type: none"> The maintenance of the equipment shall be in absence of explosive atmosphere. Clean the external parts of the mixer from dust, in order to avoid deposits of more than 5 mm.
	<p>PUTTING INTO SERVICE</p> <ul style="list-style-type: none"> Check for any leakage of oil on the shafts and mechanical seals conditions. In case of any oil leakage, contact our technical department or replace the mechanical seal.
	<p>WARNING!! <i>THESE KIND OF MIXERS MUST NOT RUN DRY EVEN IN THE INSPECTION STAGES, TESTING OR START-UP; IT IS THEREFORE NECESSARY THAT THE BUSHING/PIVOT ZONE IS SUBMERGED IN ORDER TO PERMIT A MINIMUM LUBRICATION.</i></p>

All maintenance operations must be performed after cutting off the power supply. All measures must be taken so as not to operate within the equipment when the latter is running.

The equipment must be adequately cleaned as suggested by the installer according to the features of the installation environment. Do not use solvents and/or abrasive products for cleaning, because these substances may affect the agitator’s safe operation.

During operation, the agitator does not require any special maintenance, provided that all the recommendations contained in this manual are observed.

After the first 500 hours of operation, change the oil of the agitator’s gearbox (if the latter is of the oil-lubricated type) and flush the full system after discharging the used oil. Gearboxes lubricated with synthetic grease or with oil “for life” are maintenance-free. Regularly check the lubricant level on the gearbox and change it every 4.000 operating hours, unless otherwise specified.

The lubrication of bearings (except for watertight bearings that are maintenance-free) must be performed by adding grease through the specially designed grease nipples.

The grease inside bearings must be changed when the agitator is inoperative and disconnected from the mains.

To a guarantee a longer life of the equipment, the latter must be serviced with care, replacing all parts that are more subject to wear, such as bushings, pivot, etc

6.1. AGITATOR’S COMPONENTS – OUTSIDE THE TANK

FREQUENCY	MAINTENANCE OPERATION
	MOTOR: Follow the maintenance instructions provided by the manufacturer
	GEARBOX: Follow the maintenance instructions provided by the manufacturer
	VARIATOR: Follow the maintenance instructions provided by the manufacturer
Every 6 months	FLEXIBLE COUPLINGS: Check and replace the flexible parts of the coupling, if worn.
Every 6 months	AGITATOR: Check the tightening of the bolts connecting the agitator’s flange to the tank’s flange. Check the tightening of all bolts fitted onto motion-transferring components.
Yearly	AGITATOR: Check that the outer rotor is not damage

6.2. AGITATOR’S COMPONENTS – INSIDE THE TANK

FREQUENCY	MAINTENANCE OPERATION
Every 6 months	AGITATOR: Check the conditions of bushing and eventually send the inner rotor to INOXPA
Every 6 months	AGITATOR: Check the conditions of pivot and its O-ring and eventually replace them.
Yearly	AGITATOR: Check for corrosion on the parts coming in contact with the processed products.

7. Miscellaneous

7.1. TIGHTENING TORQUES

<i>TIGHTENING TORQUE FOR BOLTS</i>			
<i>THREADING</i>	<i>MATERIAL</i>		
	<i>STAINLESS STEEL GRADE 70</i>	<i>CARBON STEEL GRADE 8.8</i>	<i>CARBON STEEL GRADE 10.9</i>
<i>M6</i>	<i>5,9 Nm</i>	<i>9 Nm</i>	<i>13,2 Nm</i>
<i>M8</i>	<i>14,5 Nm</i>	<i>21,6 Nm</i>	<i>31.8 Nm</i>
<i>M10</i>	<i>30 Nm</i>	<i>43 Nm</i>	<i>63 Nm</i>
<i>M12</i>	<i>50 Nm</i>	<i>73 Nm</i>	<i>108 Nm</i>
<i>M16</i>	<i>121 Nm</i>	<i>180 Nm</i>	<i>264 Nm</i>
<i>M20</i>	<i>224 Nm</i>	<i>363 Nm</i>	<i>517 Nm</i>
<i>M24</i>	<i>400 Nm</i>	<i>625 Nm</i>	<i>890 Nm</i>
<i>M30</i>	<i>640 Nm</i>	<i>1246 Nm</i>	<i>1775 Nm</i>
<i>M36</i>	<i>1100 Nm</i>	<i>2164 Nm</i>	<i>3082 Nm</i>

7.2. OVERHAUL

If the agitator needs to be fixed or inspected, the complete agitator unit must be sent to the following address:

INOXPA S.A.U.
 Telers, 60
 17820 – Banyoles
 Telf.: +34 972 575 200

after thoroughly checking the unit's components, the manufacturer shall advise the customer on the necessary replacements or repairs and on their costs.

7.3. SPARE PARTS

The spare parts that are mostly affected by wear are the following:

◆ **Mixer MSB type:**

- Pivot
- Guide bushings
- O-ring

Note: any of the agitator's components, if replaced, must be equivalent to the corresponding original part.

7.4. RECOMMENDATIONS

- It is strictly forbidden to operate the agitator prior to its installation.
- It is strictly forbidden to start the agitator after installation, if suitable protections have not been fitted previously to prevent access to rotating parts when the agitator is operating
- Do not tamper with/modify the agitator without the written approval of INOXPA.
- If unusual vibrations and/or noises are detected, immediately stop the agitator and check for the conditions illustrated on section 5.2 of this manual. If the problems persist, contact INOXPA.

8. Disassembly and removal

8.1. DISMANTLING SEQUENCE

Caution:

Before removing the unit make sure that there are no dangerous process conditions, such as pressure in the tank, high temperatures, aggressive or toxic products, etc.
Follow the instructions given in Chapter "4. TRANSPORT, STORAGE AND INSTALLATION" and proceed in the same way, but in reverse order.



WARNING!!! The cover of the housing of EX equipment can be opened only in a safe area or in the absence of explosive atmosphere.



CAUTION!!

- **DO NOT DAMAGE INNER AND OUTER ROTORS, PIVOT AND SHROUD DURING THE REMOVAL FROM THE ORIGINAL POSITION**

8.2. DRAINING

The equipment is made with materials that can be recycled by specialized companies.

WEEE directive 2002/96/EG

This equipment is not subject to WEEE Directive 2002/96/UE and the related national laws.

Commit the equipment directly to a company specialized in recycling and do not use municipal collection sites, which, according to the WEEE Directives 2002/96/EG, they are only for waste private material.

A proper disposal avoids damage to humans and to environment and encourages the recycle of valuable raw materials.

Directions for disposal:

- Components of mixer being scrapped: forward to collection centers authorised for metallic materials.
- Oils and lubricants: Drain at the Consortiums Exhausted Oils
- Coatings (paper, pallets, plastic, etc.): recycle through authorized companies for individual classes of refusal.

How to contact Inoxpa S.A.U.

Contact details for all countries are continually updated on our website.

Please visit www.inoxpa.com to access the information

