

INSTALLATION, SERVICE AND MAINTENANCE INSTRUCTIONS

CENTRIFUGAL PUMP

HYGINOX SE



01.011.32.0057



Original Instructions

01.011.30.11EN

(0) 2023/03

EC Declaration of Conformity



INOXPA S.A.U.

Telers, 60
17820 - Banyoles (Spain)

hereby declare under our sole responsibility that the

Machine: **CENTRIFUGAL PUMP**

Model: **HYGINOX SE**

Type: **HYGINOX SE-15, HYGINOX SE-20,
HYGINOX SE-26, HYGINOX SE-28,
HYGINOX SE-35, HYGINOX SE-36**

Serial number: **IXXXXXXXXXX to IXXXXXXXXXX
XXXXXXXXXXIINXXX to XXXXXXXXXXXXIINXXX**

fulfils all the relevant provisions of the following directive:

**Machinery Directive 2006/42/EC
Regulation (EC) n° 1935/2004
Regulation (EC) n° 2023/2006**

and with the following harmonized standards:

**EN ISO 12100:2010
EN 809:1998+A1:2009/AC:2010
EN 60204-1:2018
EN ISO 14159:2008
EN 1672-2:2005+A1:2009
EN 12162:2001+A1:2009**

The technical file has been prepared by the signer of this document.

A handwritten signature in black ink, appearing to read 'David Reyer Brunet'.

David Reyer Brunet
Technical Office Manager
8th November 2022



Document: 01.011.30.09EN

Revision: (A) 2022/11

Declaration of Conformity



INOXPA S.A.U.

Telers, 60
17820 - Banyoles (Spain)

hereby declare under our sole responsibility that the

Machine: **CENTRIFUGAL PUMP**

Model: **HYGINOX SE**

Type: **HYGINOX SE-15, HYGINOX SE-20,
HYGINOX SE-26, HYGINOX SE-28,
HYGINOX SE-35, HYGINOX SE-36**

Serial number: **IXXXXXXXXXX to IXXXXXXXXXX
XXXXXXXXXXIINXXX to XXXXXXXXXXXIINXXX**

fulfils all the relevant provisions of these regulations:

Supply of Machinery (Safety) Regulations 2008

and with the following designated standards:

**EN ISO 12100:2010
EN 809:1998+A1:2009/AC:2010
EN 60204-1:2018
EN ISO 14159:2008
EN 1672-2:2005+A1:2009
EN 12162:2001+A1:2009**

The technical file has been prepared by the signer of this document.

A handwritten signature in black ink, appearing to be 'DR' or similar initials.

David Reyer Brunet
Technical Office Manager
8th November 2022



Document: 01.011.30.10EN
Revision: (A) 2022/11

1. Table of Contents

1. Table of Contents	
2. Generalities	
2.1. Instructions manual.....	5
2.2. Compliance with the instructions.....	5
2.3. Warranty.....	5
3. Safety	
3.1. Warning symbols.....	6
3.2. General safety instructions.....	6
4. General Information	
4.1. Description.....	8
4.2. Application.....	8
5. Installation	
5.1. Reception of the pump.....	9
5.2. Identification of the pump.....	9
5.3. Transport and storage.....	10
5.4. Location.....	10
5.5. Pipes.....	11
5.6. Adjustable legs.....	11
5.7. Double mechanical seal connection.....	12
5.8. Electrical installation.....	12
6. Start-up	
6.1. Checks before starting the pump.....	14
6.2. Checks when starting the pump.....	14
7. Troubleshooting	
8. Maintenance	
8.1. General considerations.....	17
8.2. Check the mechanical seal.....	17
8.3. Maintenance of the seals.....	17
8.4. Tightening torque.....	17
8.5. Storage.....	17
8.6. Cleaning.....	18
8.7. Disassembly and assembly of the pump.....	19
9. Technical Specifications	
9.1. Noise level.....	26
9.2. Weights.....	27
9.3. Dimensions.....	27
9.4. Exploded drawing.....	29
9.5. Double mechanical seal.....	31

2. Generalities

2.1. INSTRUCTIONS MANUAL

This manual contains information about the reception, installation, operation, assembly and maintenance of the Hyginox SE pump.

Carefully read the instruction before starting the blender, familiarize yourself with the installation, operation and correct use of the pump and strictly follow the instructions. These instructions should be kept in a safe location near the installation area.

The information published in the instruction manual is based on updated data.

INOXPA reserves the right to modify this instruction manual without prior notice.

2.2. COMPLIANCE WITH THE INSTRUCTIONS

Not following the instructions may impose a risk for the operators, the environment and the machine, and may cause the loss of the right to claim damages.

This non-compliance may cause the following risks:

- failure of important machine/plant functions,
- failure of specific maintenance and repair procedures,
- possible electrical, mechanical and chemical hazards,
- the risk to the environment due to the type of substances released.

2.3. WARRANTY

The conditions of the warranty are specified in the General Sales Condition that has been delivered at the time of placing your order.



The machine may not undergo any modification without prior approval from the manufacturer.

For your safety, only use original spare parts and accessories. The usage of other parts will relieve the manufacturer of any liability.

Changing the service conditions can only be carried out with prior written authorization from INOXPA.

The non-compliance of the prescribed indications in this manual means misuse of this gear on the technical side and the personal safety and this, exempts INOXPA of all responsibility in case of accidents and personal injuries and/or property damage. Also, excluded from the warranty all breakdowns caused by improper use of the gear.

Please do not hesitate to contact us in case of doubts or if further explanations are required regarding specific data (adjustments, assembly, disassembly, etc.).

3. Safety

3.1. WARNING SYMBOLS



Safety hazard for people in general and/or for the equipment



Electric hazard

ATTENTION

Important instruction to prevent damage to the equipment and/or its function

3.2. GENERAL SAFETY INSTRUCTIONS



Read the instruction manual carefully before installing and starting the pump. Contact INOXPA in case of doubt.

3.2.1. During installation



Always take into account the [Technical Specifications of chapter 9](#).
Never start the pump before connecting it to the lines.
Do not start up the pump if the pump cover is not fitted.



During the installation, all the electric work should be carried out by authorized personnel.
Check for proper motor specifications, especially if the working conditions create an explosion hazard.

3.2.2. During operation



The [Technical Specifications of chapter 9](#) should always be observed. Under no circumstances can the specified limit values be exceeded.
NEVER touch the pump or the pipework during operation if the pump is being used for transferring hot liquids or during cleaning.
The pump contains moving parts. Never place your fingers inside the pump during operation.
NEVER operate with the suction and discharge valves closed.
NEVER spray water directly on the electrical motor. The standard motor protection is IP55: protection against dust and water spray.

3.2.3. During maintenance



The [Technical Specifications of chapter 9](#) shall always be observed. NEVER disassemble the pump until the pipes have been emptied. Remember that liquid will remain inside the pump's pump casing (if does not have a purge). Bear in mind that the product may be hazardous or extremely hot. Consult the regulations in effect in each country for these cases.

Do not leave loose parts on the floor.



ALWAYS disconnect the electrical power to the pump prior to carrying out any maintenance.

Remove the fuses and disconnect the cable from the motor's terminals.

All electrical work must be carried out by authorized personnel.

4. General Information

4.1. DESCRIPTION

HYGINOX SE is a range of close-coupled centrifugal pumps with a hygienic design. This single-stage horizontal pump has a circular casing with axial suction and a tangential discharge. The main pump components are a pump casing, impeller, cover, lantern and shaft which is rigidly coupled to the motor shaft.

The standard IEC motor of type IM B34 or B35 is protected by a stainless steel shroud and provided with height adjustable stainless steel legs.

4.2. APPLICATION

As a general rule, HYGINOX SE pumps, in their standard versions, are used in the food industry mainly to transfer liquids.

For each type of pump, the hydraulic performance is given by the choice of impeller diameters and speeds. The characteristic curves also show the power and NPSH requirements. The intended use of the pump is defined by its characteristic curve and operating limits provided in the [9. Technical Specifications](#).

ATTENTION



The range of application for each type of pump is limited. The pump was selected for a given set of pumping conditions when the order was placed. Misuse or its use beyond the operating limits may be dangerous or cause permanent damage to the equipment. INOXPA shall not be liable for any damage resulting from the incompleteness of the information provided by the purchaser (nature of the fluid, rpm, etc.)

5. Installation

5.1. RECEPTION OF THE PUMP



INOXPA cannot be held responsible for the damage sustained by the equipment during transport or unpacking. Please visually check that the packaging is not damaged.

The pump package includes the following documents:

- shipping documents,
- quick installation guide,
- instructions and service manual of the motor¹

1) if the pump has been supplied with a motor from INOXPA

Unpack the pump and check the following:

- the suction and discharge connections of the pump removing any rest of the packaging material,

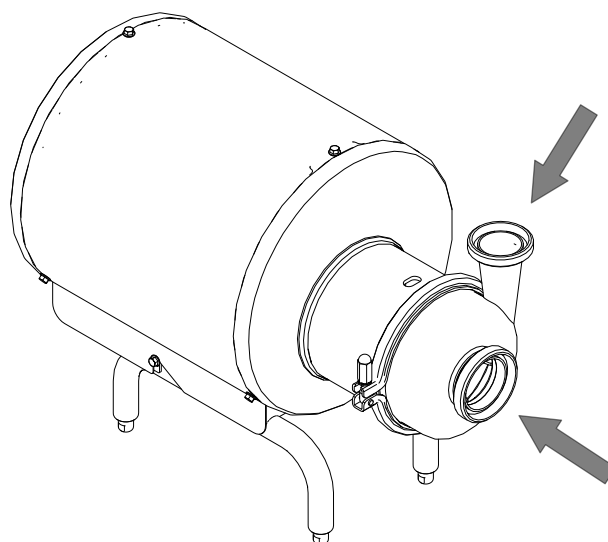

- the pump is not damaged,

If the equipment is not in good condition and/or any part is missing, the carrier should report accordingly as soon as possible.

5.2. IDENTIFICATION OF THE PUMP

Each pump has a nameplate with the basic data required to identify the model.



5.3. TRANSPORT AND STORAGE

ATTENTION



The HYGINOX SE pumps are often too heavy to be stored manually. Use an appropriate means of transport. Use the points which are indicated in the drawing for lifting the pump. Only authorized personnel should transport the pump. Do not work or walk under the heavy loads.

Lift the pump as indicated below:

- always use two support points placed as far apart as possible.

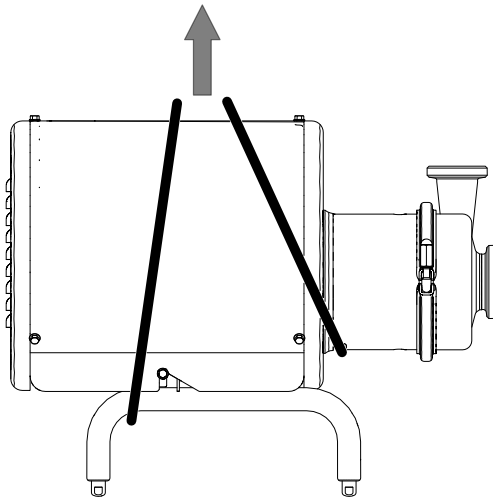

01.011.32.0022

ATTENTION



Always remove the motor shroud before hoisting.

- secure the supports so that they will not move.

See chapter 9. [Technical Specifications](#) to consult the dimensions and weight of the pump.

ATTENTION



During the transport, disassembly or assembly of the pump, there is a risk of loss of stability and that the pump could fall down and cause damages to the operators. Make sure that the pump is properly supported.

5.4. LOCATION

Place the pump in a position that allows enough space around it to provide access to the pump as well as to the motor. For the pumps with legs, consult in chapter 9. [Technical Specifications](#) the dimensions and the weights of the pump. For the pumps with double mechanical seal and without legs, respect the minimum distance respect to the floor represented in the following figure:

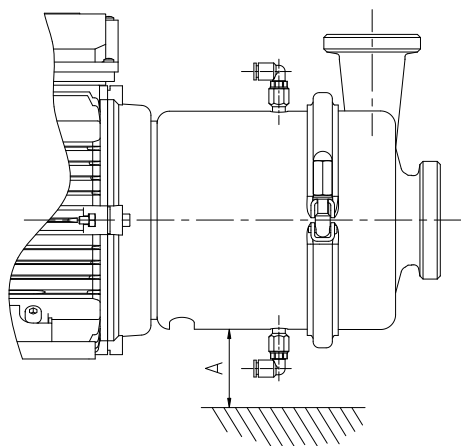

01.011.32.0037

Bomba	A (mm)
SE-15	50
SE-20/26	50
SE-28/35/36	70

Place the pump on a flat and level surface.

ATTENTION



Install the pump so as to allow proper ventilation. If the pump is installed outdoors, it should be covered by a roof. Its location should allow easy access for inspection or maintenance operations.

5.4.1. Excessive temperatures

Depending on the fluid to be pumped, high temperatures can be reached inside and around the pump.



Over 68°C the operator should take protective measures and place warning notices advising of the danger which exists if the pump is touched. The type of protection selected should not isolate the pump entirely.

5.6. ADJUSTABLE LEGS

To keep the adjustable legs thread clean these are the permissible L values:

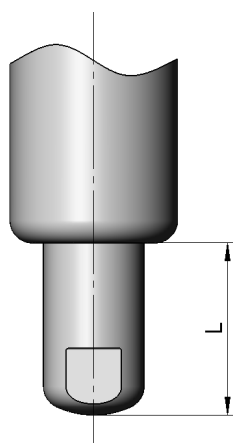

01.030.32.0008

Motor size	Adjustable legs	L min. (mm)	L max. (mm)
71	M12	8	23
80/90	M12	8	23
100/112	M16	10	30
132	M16	10	30
160/180	M20	13	40
200/225	M20	13	40

5.5. PIPES

About the installation pipes:

- as a general rule, install the suction and discharge lines in straight sections, with the minimum possible number of elbows and fittings to reduce any pressure losses that may be caused by friction,
- make sure that the pump's ports are properly aligned with the pipework and have a diameter similar to that of the pump connections,
- place the pump as close as possible to the suction tank and whenever possible below the liquid level or even below the tank level in order to achieve the largest possible static head for suction,

- install support brackets for the lines as close as possible to the pump's suction and discharge ports in order to avoid vibrations and stress of the pump.

5.6.1. Shut-off valves

The pump may be isolated for maintenance. To accomplish this, shut-off valves must be installed and connected to the blender's suction and discharge connections.



ATTENTION

These valves must ALWAYS be open during operation of the pump.

5.7. DOUBLE MECHANICAL SEAL CONNECTION

If the pump has a double mechanical seal, the auxiliary liquid entry should be connected to the pump bottom part connection, as shown in the following figure:

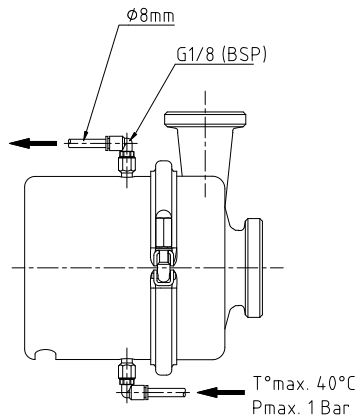

01.011.32.0055

5.8. ELECTRICAL INSTALLATION



Only qualified personnel can connect the electric motors. Take the necessary measures to prevent damage to cables and connections.



Electrical equipment, terminals and components of the control systems may still carry current when they are disconnected. Contacting them may impose a hazard to operators or cause irreparable material damage. Before handling the pump, make sure that the motor is stopped.

To do the electrical installation:

- connect the motor in accordance with the instructions supplied by the motor manufacturer, in accordance with the current national legislation and in compliance with EN 60204-1,
- check the direction of rotation (see the signalling label on the pump),
- start and stop the pump motor momentarily. Make sure, looking at the pump by the hopper side, that the rotation direction of the motor fan is counterclockwise.

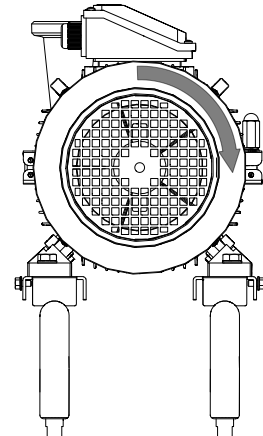

01.011.32.0023

**ATTENTION**

See the indicator label on the pump.
ALWAYS check the direction of rotation of the motor with liquid inside the pump.

6. Start-up



Before starting the pump, carefully read the instructions in section [5. Installation](#). Carefully read section [9. Technical Specifications](#). INOXPA will not be liable for improper use of the equipment.



NEVER touch the pump or the lines of hot liquids that are being mixed.

6.1. CHECKS BEFORE STARTING THE PUMP

Before starting the pump:

- completely open the shut-off valves on the suction and discharge lines,
- if the liquid does not flow towards the pump, fill it with the liquid to be pumped,
- for the pumps equipped with a double mechanical seal, sure the correct circulation of the cooling liquid,

ATTENTION



The pump must never turn dry.
For the pumps equipped with a double mechanical seal, sure the correct circulation of the cooling liquid.

- check that the power supply matches the rating indicated on the motor plate,
- check that the motor rotation direction is correct,

6.2. CHECKS WHEN STARTING THE PUMP

When starting the pump check:

- that the pump is not making any strange noises,
- if the absolute inlet pressure is sufficient to prevent cavitation in the pump. See the curve to determine the minimum pressure required above steam pressure (NPSHr),
- the discharge pressure,
- that there are no leaks in the sealing areas.

ATTENTION



Shut-off valves on the suction pipe must not be used to regulate the flow. All shut-off valves must be fully open during operation.

ATTENTION



Control the motor consumption to prevent an electrical overload.

Reduce the flow rate and the electrical power consumed by the motor:

- by regulating the pump's discharge flow,
- by decreasing the motor speed.

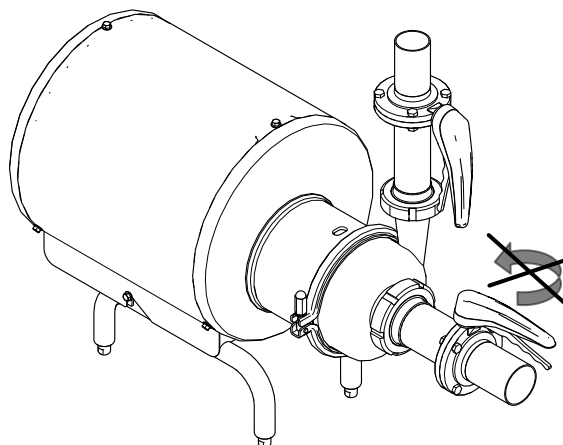

01.011.32.0048



Use special protection when the sound pressure in the operation area exceeds 85 dB(A).

7. Troubleshooting

The following table provides solutions to problems that might arise during the operation of the pump. The pump is assumed to have been properly installed and be suitable for the relevant application. Please contact INOXPA if technical assistance is required.

Motor overload					
The pump does not provide enough flow or pressure					
No pressure on the discharge side					
Uneven discharge flow / pressure					
Noise and vibration					
The pump gets clogged					
Overheated pump					
Excessive wear					
The mechanical seal leaks					
		PROBABLE CAUSES		SOLUTIONS	
•	•	Wrong direction of rotation		- Reverse the direction of rotation	
•	•	•	•	NPSH is not high enough	
	•	Pump not drained		- Drain or fill	
•	•	•	•	Cavitation	
•	•	•	•	Air is suctioned by the pump	
	•	•	•	Clogged suctioned pipe	
•	•	Discharge pressure too high		- If necessary, reduce load losses, e.g. by increasing the pipe diameter	
•	•	•	•	Flow too high	
•	•	•	•	Fluid viscosity too high	
•	•	•	•	Fluid temperature too high	
		•	•	Mechanical seal damaged or worn out	
		•	•	O-rings unsuitable for the fluid	
•	•	•	•	The impeller scrapes	
	•	•	•	Tension in the lines	
	•	•	•	Foreign matter in the liquid	
		•	•	Mechanical seal spring tension is too low	
				- Adjust as indicated in this manual	

8. Maintenance

8.1. GENERAL CONSIDERATIONS

This pump, just like any other machine, requires maintenance. The instructions contained in this manual cover the identification and replacement of spare parts. The instructions are aimed at maintenance personnel and those responsible for the supply of spare parts.



Carefully read chapter 9. [Technical Specifications](#).
Maintenance work can only be carried out by qualified personnel that are trained and equipped with the necessary resources to carry out this work.
All parts or materials that are replaced must be properly disposed of/recycled in accordance with the current directives applicable in each area.



ALWAYS disconnect the blender before beginning any maintenance work.

8.2. CHECK THE MECHANICAL SEAL

Periodically check that there are no leaks around the shaft. If leakage is detected through the mechanical seal, replace it following the instructions in chapter 8.7. [Disassembly and assembly of the pump](#).

8.3. MAINTENANCE OF THE SEALS

SEALS REPLACEMENT

Preventive maintenance	Replace after twelve (12) months. We also recommend replacing the gaskets during mechanical seal replacement.
Maintenance after a leak	Replace at the end of the process
Scheduled maintenance	Regularly check that there are no leaks and that the blender is operating correctly. Keep a maintenance record of the pump. Use statistics to plan inspections.
Lubrication	During assembly, use soapy water or oil compatible for the food industry when fitting the different gaskets to allow them to slide better.

The period between each preventive maintenance service will vary depending on the operating condition of the pump: temperature, flow, number of operating hours, cleaning solutions used, etc.

8.4. TIGHTENING TORQUE

Size	Nm	lbf-ft
M6	10	7
M8	21	16
M10	42	31
M12	74	55
M16	112	83

8.5. STORAGE

Before being stored the pump must be completely emptied of liquids. Avoid, as far as possible, the exposure of the parts to excessively damp atmospheres.

8.6. CLEANING



The use of aggressive cleaning products such as caustic soda and nitric acid may give raise to skin burns.

Use rubber gloves during cleaning procedures.
Always use protective goggles.

8.6.1. Automatic CIP (clean-in-place)

If the pump is installed in a system with a CIP process, it is not necessary to disassemble the blender. If the automatic cleaning process is not provided, proceed to disassemble the blender as indicated in the chapter [8.7. Disassembly and assembly of the pump](#).

Two types of solutions can be used for CIP processes:

a. alkaline solution: 1% by weight of caustic soda NaOH a 70°C (150°F). To make this solution:
1 kg NaOH + 100 l H₂O¹ = cleaning solution
2,2 l NaOH 33% + 100 l H₂O = cleaning solution

b. acid solution: 0,5% by weight of nitric acid HNO₃ a 70°C (150°F). To make this solution:
0,7 l HNO₃ 53% + 100 l H₂O = cleaning solution

1) only use chlorine-free water to mix with the cleaning agents

ATTENTION



Check the concentration of the cleaning solutions. Incorrect concentrations may lead to the deterioration of the blender seals.

To remove any traces of cleaning products ALWAYS perform a final rinse with clean water at the end of the cleaning process.

8.6.2. Automatic SIP (sterilization-in-place)

The steam sterilisation process is applied to all equipment including the pump.

ATTENTION



Do NOT operate the equipment during the steam sterilisation process.

The parts and the materials will not suffer damage provided the instructions set out in this manual are followed.

Cold liquid cannot be introduced until the pump temperature is below 60°C (140°F).

The blender generates a substantial pressure loss through the sterilisation process. We recommend the use of a bypass circuit provided with a discharge valve to ensure that the steam or overheated water sterilises the entire circuit.

Maximum conditions during the steam or overheated water SIP process:

- a. maximum temperature: 140°C / 284°F
- b. maximum time: 30 min
- c. cooling: sterile air or inter gas
- d. materials: EPDM (recommended)
FPM (use with caution)

8.7. DISASSEMBLY AND ASSEMBLY OF THE PUMP

The assembly and disassembly of the pump should be done by qualified personnel. Make sure that the personnel read carefully this instruction manual and, in particular, those instructions which refer to the work they will perform.

ATTENTION



Incorrect assembly or disassembly may cause damage in the blender's operation and lead to high repair costs and a long period of downtime.

INOXPA is not responsible for accidents or damages caused by a failure to comply with the instructions in this manual.

Preparation

Provide for a clean working environment so some parts, including the mechanical seal, require very careful handling and others have close tolerances.

Check that the parts which are used are not damaged during transport. When doing this, you need to inspect the adjustment edge, the butted faces, the tight fit, burrs, etc.

After each disassembly, carefully clean the parts and check for any damage. Replace all damaged parts.

Tools

Use the proper tools for assembly and disassembly operations. Use them correctly.

Cleaning

Before disassembling the pump, clean it outside and inside.

8.7.1. Pump with mechanical seal

Disassembly

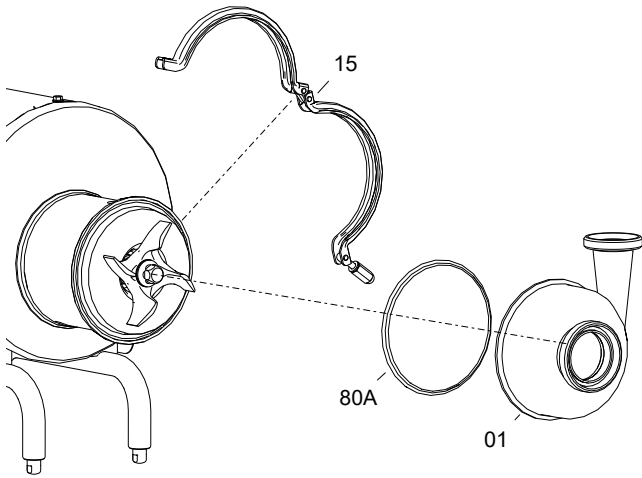

1. Remove the clamping ring (15) and disassemble the pump casing (01).
2. Check the state of the O-ring (80A) of the pump casing and replace it if damaged.

01.011.32.0024

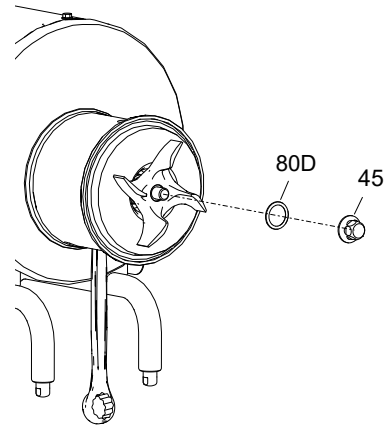

3. Immobilize the shaft (05) placing the open-end wrench (45) between the flat sides.
4. Disassemble the impeller nut (45) and its O-ring.

01.011.32.0025

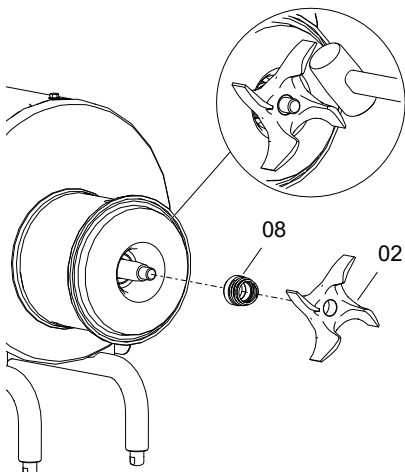

5. Disassemble the impeller (02). If necessary, hit it with a plastic mallet to disengage it.
6. Remove the rotating part of the mechanical seal (08) from the back part of the impeller (02).

01.011.32.0026

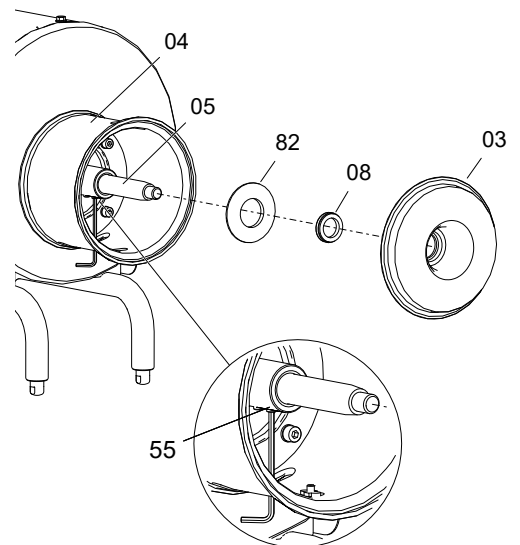

7. Remove the cover pump (03) from the lantern (04).
8. Manually remove the stationary part of the mechanical seal (08) from the pump cover.
9. Remove the splash ring (82) from the shaft (05).
10. Place the shaft (05) so the two studs (55) are at the bottom part and loosen them with an allen screw.
11. Remove the shaft (05) from the motor (93).

01.011.32.0027

Assembly

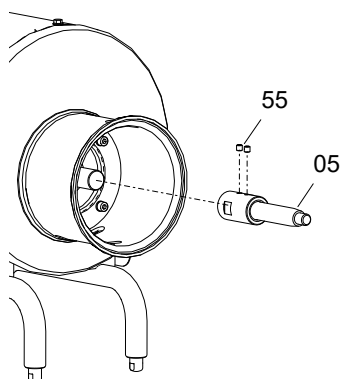

01.011.32.0029

1. Mount the shaft (05) on the motor (93).
2. Fix the shaft (05) with the studs (55) to the motor (93). Leave the shaft a bit loose to be able to gauge the impeller (02) with the cover (03).

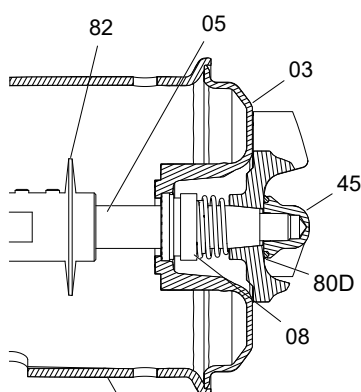

01.011.32.0031

7. Mount the splash ring (82) to the shaft (05).
8. Place the stationary part of the mechanical seal (08) on the cover (03).
9. Mount the cover (03) on the lantern (04).
10. Slide the rotating part of the mechanical seal (08) on the shaft (05) and place the impeller (02).
11. Place the O-ring (80D) on the impeller nut (45) and fix the shaft (02) with the impeller nut (45).

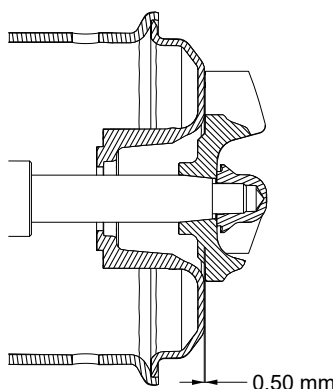

01.011.32.0030

3. Enter the pump cover (03) on the lantern centring (04).
4. Mount the impeller (02) on the shaft, fix it with the impeller nut (45) and gauge the assembly position according to picture 01.011.32.0030.
5. Tighten the studs (55) that fix the shaft (05) to the motor (93).
6. Unscrew the impeller nut (45) and remove the impeller (02) and the cover (03).

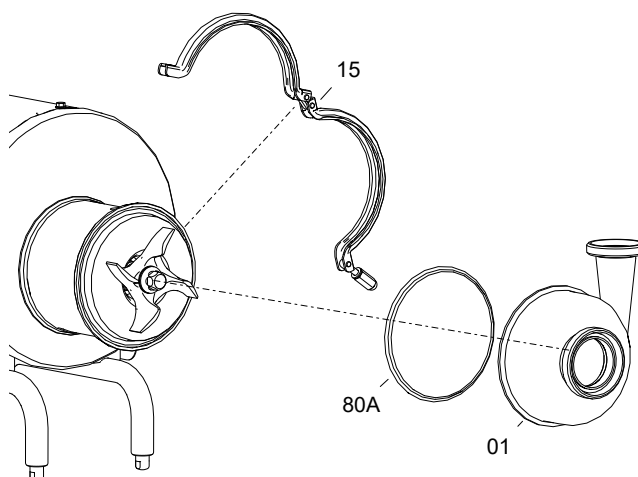

01.011.32.0024

12. Mount the O-ring (80A) on the cover (03) ensuring that it is not twisted.
13. Place the pump casing (01) and fix the lantern (04) with the clamping ring (15) and tighten the nut strongly.

ATTENTION



When installing the new seal, use soapy water when fitting the different parts and gaskets to allow them to slide better. Apply to the stationary as well as the rotating parts.

8.7.2. Pump with double mechanical seal

Disassembly

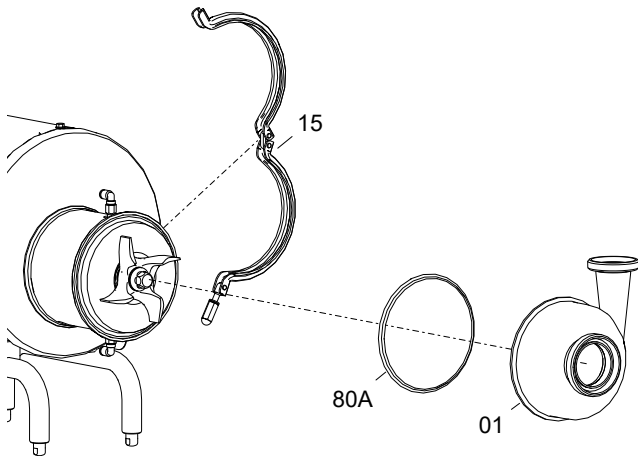

1. Remove the clamping ring (15) and disassemble the pump casing (01).
2. Check the state of the O-ring (80A) of the pump casing and replace it if damaged.

01.011.32.0032

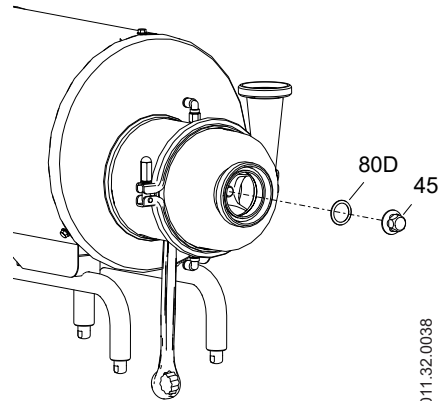

3. Immobilize the shaft (05) placing the open-end wrench (45) between the flat sides.
4. Disassemble the impeller nut (45) and its O-ring.

01.011.32.0038

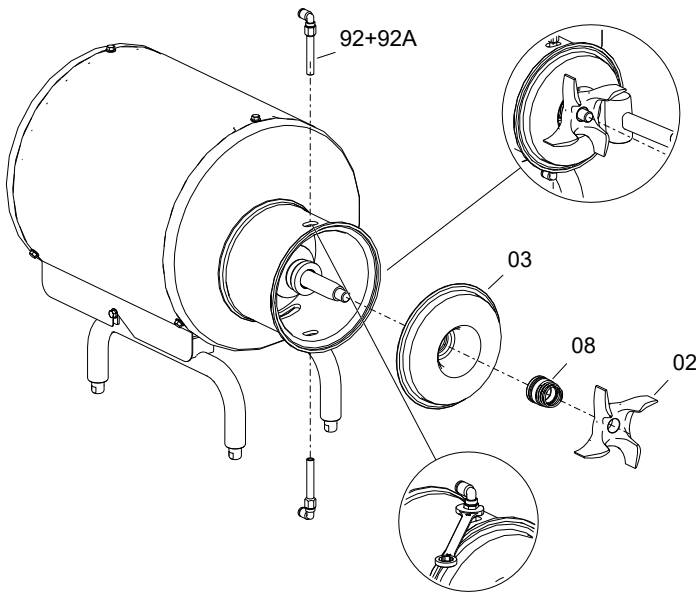

5. Disassemble the impeller (02). If necessary, hit it with a plastic mallet to disengage it.
6. Remove the rotating part of the mechanical seal (08) from the back part of the impeller (02).
7. Loose the couplings (92,92A) and remove them.
8. Remove the assembly formed by the pump cover (03), the rotating part of the mechanical seal (08), the double mechanical seal cover (10) and the stationary part of the double mechanical seal (08A).

01.011.32.0039

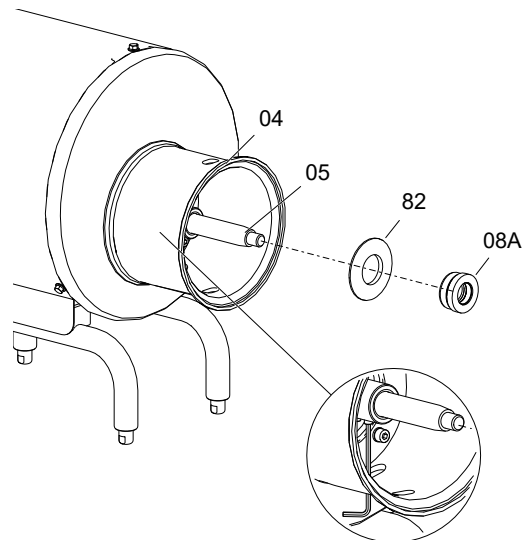

9. Remove the stationary part of the double mechanical seal (08A).
10. Remove the splash ring (82) del eje (05).
11. Place the shaft (05) so the two studs (55) are at the bottom part and loosen them with a 4 mm allen screw in order to remove the shaft (05).

01.011.32.0040

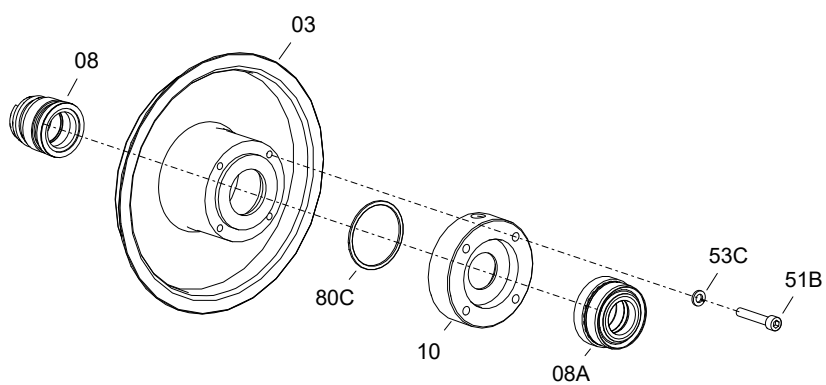

01.011.32.0041

12. Loosen the screws (51B) and remove them with their grower washers (53C).
13. Separate the stationary parts of the mechanical seals (08,08A) from the pump cover (03), the double mechanical seal cover (10) and the O-ring (80C).

Montaje

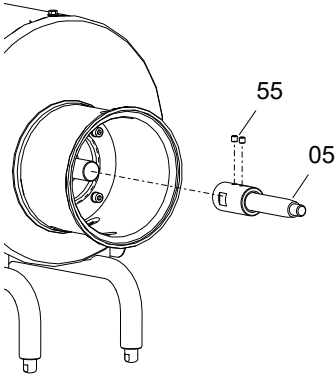

01.011.32.0029

1. Mount the shaft (05) on the motor (93).
2. Fix the shaft (05) with the studs (55) to the motor (93). Leave the shaft a bit loose to be able to gauge the impeller (02) with the cover (03).

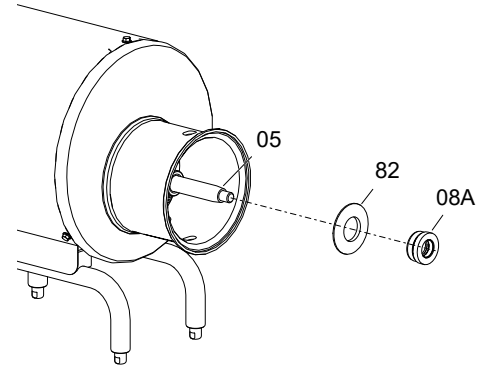

01.011.32.0042

3. Place the splash ring (82) and the stationary part of the double mechanical seal (08A) on the shaft (05).

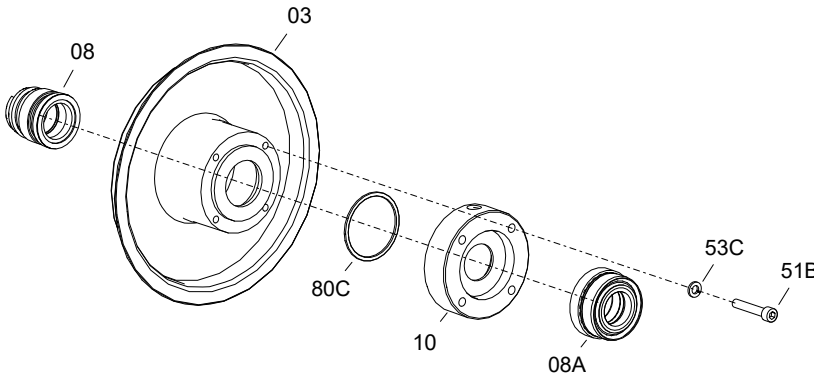

01.011.32.0041

4. Mount the O-ring (80C) on the double mechanical seal cover (10).
5. Place the double mechanical seal cover (10) on the pump cover (03) and fix it with the screws (51B) and the washers (53C).
6. Place the rotating part of the double mechanical seal (08A) on the double mechanical seal cover (10).
7. Place the stationary part of the mechanical seal (08) on the pump cover (03).

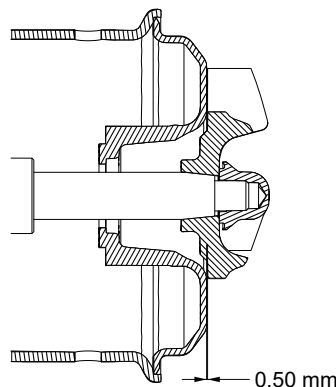

01.011.32.0030

8. Enter the pump cover (03) on the lantern centring (04).
9. Mount the impeller (02) on the shaft, fix it with the impeller nut (45) and gauge the assembly position according to picture 01.011.32.0030.
10. Tighten the studs (55) that fix the shaft (05) to the motor (93).
11. Unscrew the impeller nut (45) and remove the impeller (02) and the cover (03).

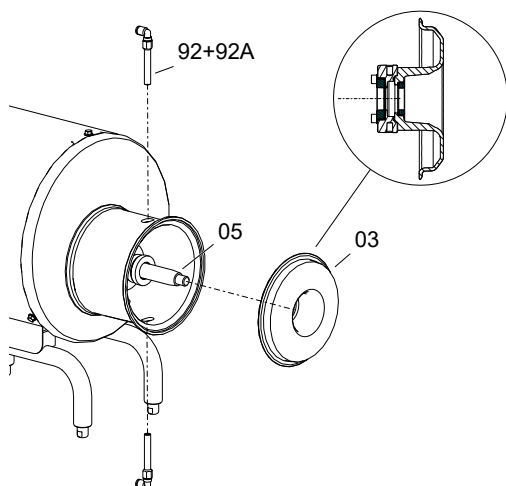

01.011.32.0043

12. Mount the pump cover assembly on the shaft (05). Ensure that the screws of the double mechanical seal cover (10) are aligned with the lantern holes (04).
13. Mount the upper coupling (92,92A).
14. Mount the bottom coupling (92,92A). If there is a too small distance between the lantern (04) and the floor, you can introduce the coupling inclined in the lantern, and when it is possible, put it in a vertical position.

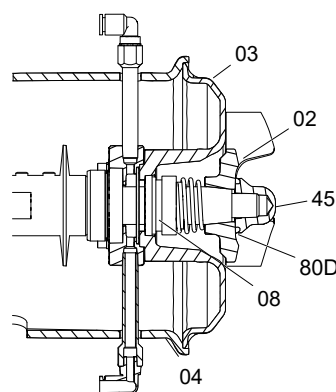

01.011.32.0053

15. Mount the cover (03) on the lantern (04).
16. Slide the rotating part of the mechanical seal (08) on the shaft (05) and place the impeller (02).
17. Place the O-ring (80D) on the impeller nut (45) and fix the shaft (02) with the impeller nut (45).

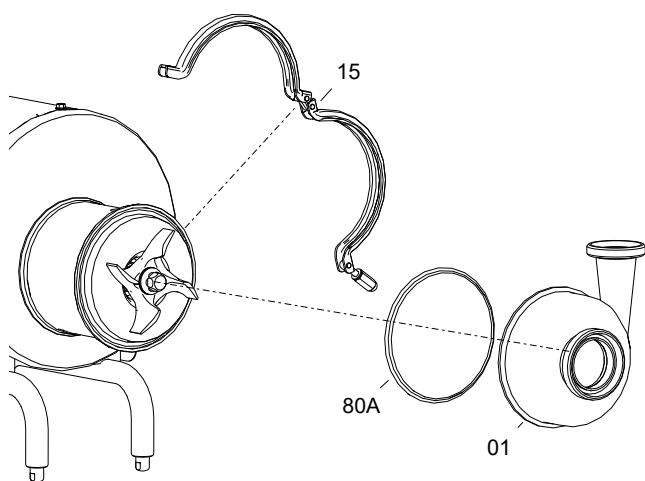

01.011.32.0024

18. Mount the O-ring (80A) on the cover (03) ensuring that it is not twisted.
19. Place the pump casing (01) and fix the lantern (04) with the clamping ring (15) and tighten the nut strongly.

ATTENTION



When installing the new seal, use soapy water when fitting the different parts and gaskets to allow them to slide better. Apply to the stationary as well as the rotating parts.

9. Technical Specifications

Maximum operating pressure	1000 kPa (10 bar)
Temperature range	-10°C to 120°C (EPDM)
Maximum speed	3000 rpm (50 Hz) 3600 rpm (60 Hz)

Materials

Parts in contact with the product	1.4404 (AISI 316L)
Other stainless steel parts	1.4307 (AISI 304L)
Seals in contact with the product	EPDM - standard FPM (consult other materials)
Other seals	NBR
External surface finish	matt
Internal surface finish	polished $Ra \leq 0,8 \mu m$

Mechanical seal

Type	internal single or double seal
Rotating part materials	graphite (C) - standard silicon carbide (SiC)
Stationary part materials	silicon carbide (SiC)
Seal materials	EPDM - standard FPM

Double mechanical seal

Arrangement	tandem
Auxiliary (buffer) liquid consumption	5 - 10 l/h
Maximum working pressure	10 KPa (1 bar)
Maximum working temperature	40°C
Ø connection	G 1/8

Motor

Type	three-phase asynchronous motor, IEC B34 type, 2 or 4 poles, IP55 protection, class F insulation. The type of motor will be IECB35 for motor sizes 80 and 90 in Hyginox SE-15 pumps and for motor sizes 132 and 160 for all kinds of pumps.
Power	0,37 to 15 kW
Voltage and frequency	220-240 V Δ / 380-420 V Y, ≤ 4 kW 380-420 V Δ / 660-690 V Y, $\geq 5,5$ kW

9.1. NOISE LEVEL

The indicated noise levels correspond to the standard pump, with maximum impeller and shrouded motor, running at approximately 2900 rpm, at the point of best efficiency and with a motor with sufficient power.

These values were taken at a distance of 1 m from the pump and at a height of 1,6 m above the floor level. The measurements were carried out according to the standard EN 12639 / ISO 3746 Grade 3 with a tolerance of ± 3 dB(A).

Pump	Motor power (kW)	Sound pressure LpA dB(A)	Sound power LwA dB(A)
SE-15	0,55	64	
SE-20	2,2	69	
SE-26	5,5	77	
SE-28	7,5	79	
SE-35	11	81	94
SE-36	15	83	97

It must be borne in mind that the noise levels can greatly increase if reducers, elbows or other fittings are installed near the pump.

9.2. WEIGHTS

IEC	Weight (kg)																	
	71		80		90		100		112		132		160					
kW	0,25	0,37	0,55	0,75	1,1	1,1	1,5	2,2	2,2	3	4	5,5	5,5	7,5	11	11	15	
SE-15	16	17	17	24	26	30												
SE-20						32	31	33		45	51							
SE-26						33	32	34		45	52	58	73	81				
SE-28						38	37	39		50	57	63	78	86				
SE-35										51	56	63	64	78	57	100	136	156
SE-36										54	59	65	66	80	90	103	138	158

9.3. DIMENSIONS

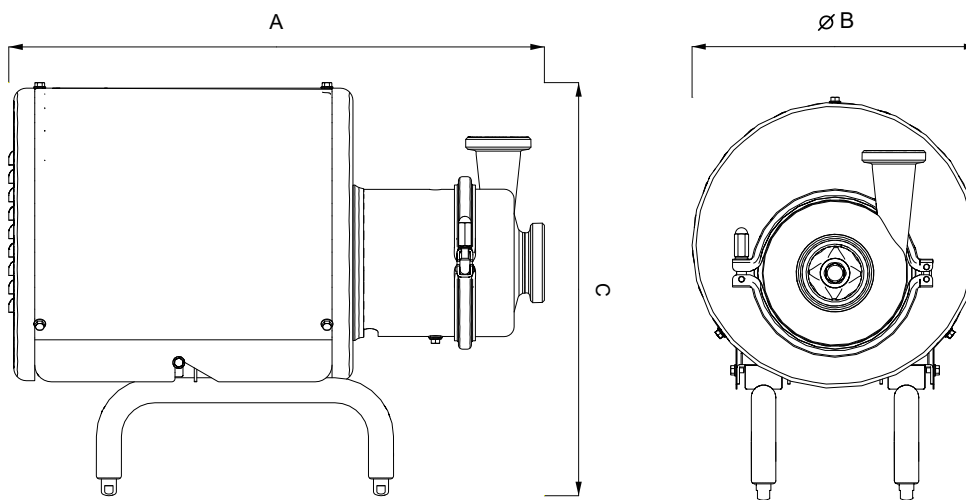

Pump	Motor		Dimensions (mm)		
	IEC	kW	A	ØB	C
SE-15	71	0,25	470	230	350
		0,37			
		0,55			
	80	0,75	560	290	405
		1,1			
90	1,5			415	

Pump	Motor		Dimensions (mm)		
	IEC	kW	A	ØB	C
SE-20	90	1,1	560	290	415
		1,5			
		2,2			
	100	3	635	350	480
		4			490
SE-26	90	1,1	570	290	415
		1,5			
		2,2			
	100	3	640	350	480
		4			490
	132	5,5	770	400	530
5,5					
7,5					
SE-28	90	1,1	565	290	415
		1,5			
		2,2			
	100	3	640	350	480
		4			490
	132	5,5	770	400	530
5,5					
7,5					
SE-35	100	2,2	650	350	480
		3			490
		4			
	112	5,5	780	400	530
		5,5			
		7,5			
160	11	915	465	645	
	11				
	15				
SE-36	100	2,2	650	350	350
		3			
		4			
	112	5,5	780	400	400
		5,5			
	132	7,5	915	465	465
		11			
11					

9.4. EXPLODED DRAWING

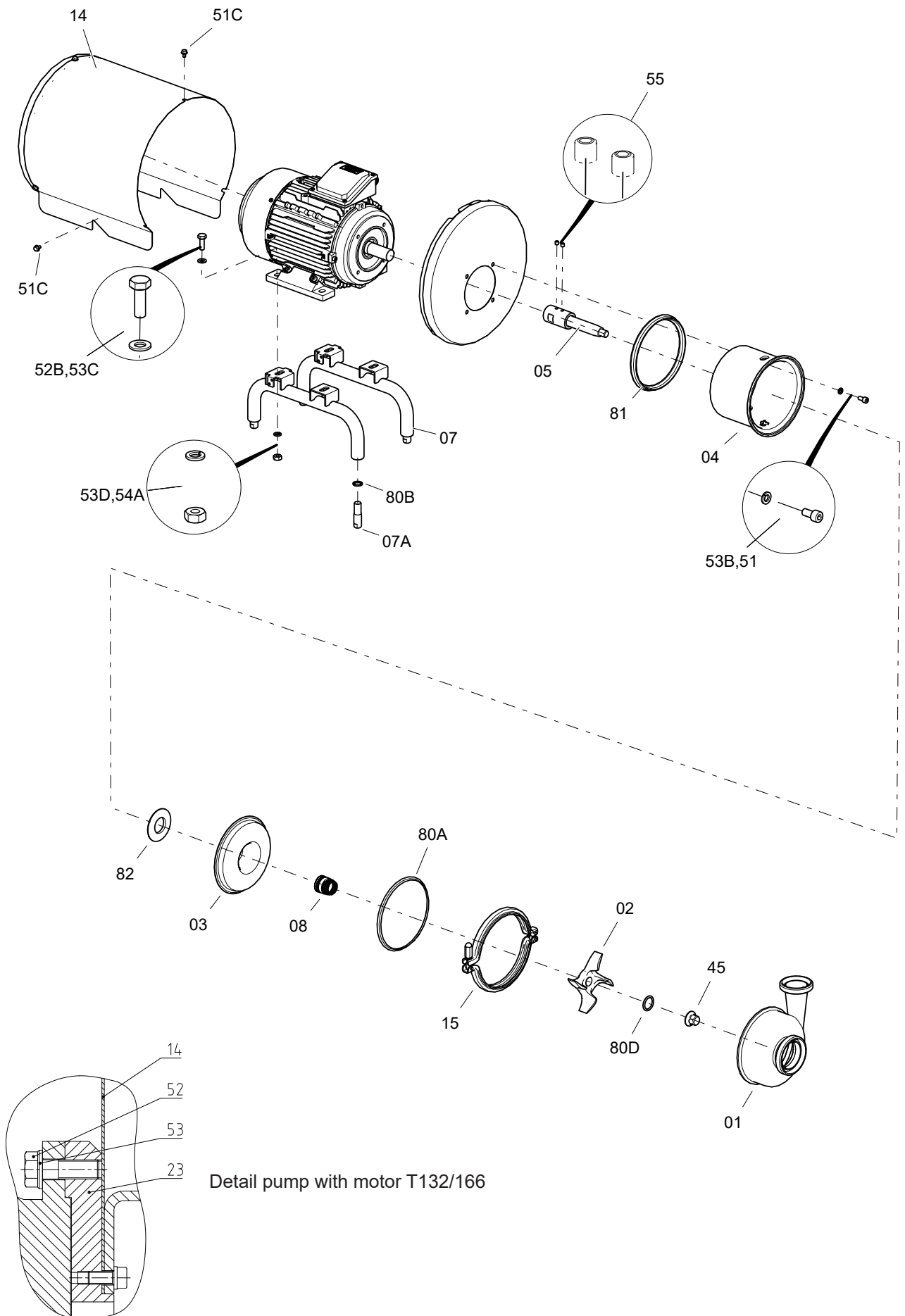

01.011.32.0044

Position	Description	Quantity	Material
01	casing	1	1.4404 (AISI 316L)
02	impeller	1	1.4404 (AISI 316L)
03	cover	1	1.4404 (AISI 316L)
04	lantern	1	1.4301 (AISI 304)
05	shaft	1	1.4404 (AISI 316L)
07	motor leg	2	1.4301 (AISI 304)
07A	adjustable leg	4	1.4301 (AISI 304)
08	mechanical seal ¹	1	-
14	shroud	1	1.4301 (AISI 304)
15	casing clamp	1	1.4301 (AISI 304)
45	cap nut	1	1.4404 (AISI 316L)
51	allen screw	4	A2
51C	screw with flange	8	A2
52B	hexagonal screw	4	A2
53B	grower washer	4	A2
53C	flat washer	8	A2
53D	grower washer	4	A2
54A	hexagonal nut	4	A2
55	stud	2	A2
80A	O-ring ¹	1	EPDM
80B	O-ring ¹	4	NBR
80D	O-ring ¹	1	EPDM
81	O-ring ¹	1	EPDM
82	splash ring ¹	1	EPDM
93	motor	1	-

1) Recommended spare parts

Piezas solo para bombas con tamaño de motor 132 y 160

Position	Description	Quantity	Material
23	counterflange	1	LM4
52	hexagonal screw	1	A2
53	flat washer	1	A2

9.5. DOUBLE MECHANICAL SEAL

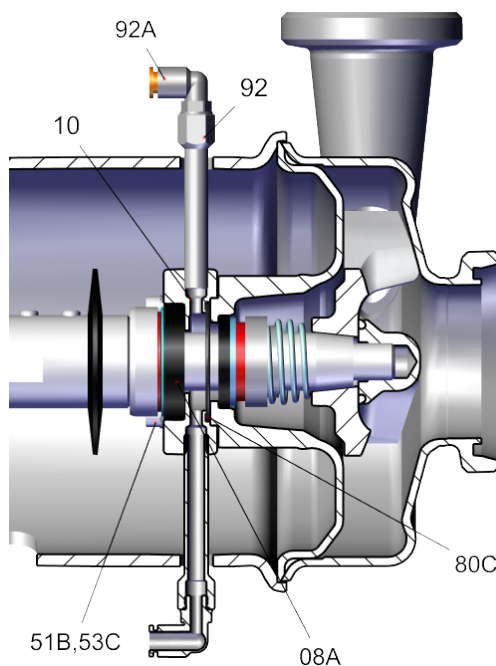

01.011.32.0045

Position	Description	Quantity	Material
08A	double mechanical seal ¹	1	-
10	double mechanical seal cover	1	1.4404 (AISI 316L)
51B	allen screw	4	A2
53C	grower washer	4	A2
80C	O-ring ¹	1	EPDM
92	coupling	2	1.4301 (AISI 304)
92A	rotary male bend for tube Ø8 mm		

1) Recommended spare parts

How to contact INOXPA S.A.U.:

Contact details for all countries are continually updated on our website

Please visit www.inoxpa.com to access the information.



INOXPA S.A.U.
Telers, 60 - 17820 - Banyoles - Spain

