



## **INSTALLATION, SERVICE AND MAINTENANCE INSTRUCTIONS**

# **OVERFLOW VALVE**



### **INOXPA, S.A.**

c/Telers, 54 Aptdo. 174

E-17820 Banyoles

Girona (Spain)

Tel. : (34) 972 - 57 52 00

Fax. : (34) 972 - 57 55 02

Email: [inoxpa@inoxpa.com](mailto:inoxpa@inoxpa.com)

[www.inoxpa.com](http://www.inoxpa.com)

Original Manual

10.207.30.00EN  
(E) 2022/07

# EC Declaration of Conformity



**INOXPA S.A.U.**

Telers, 60  
17820 - Banyoles (Spain)

hereby declare under our sole responsibility that the

Machine:	<b>VALVE</b>
Model:	<b>OVERFLOW VALVE</b>
Type:	<b>74700</b>
Size:	<b>DN 25 - DN 80 / OD 1" - OD 3"</b>
Serial number:	<b>IXXXXXXXXXX to IXXXXXXXXXX XXXXXXXXXXIINXXX to XXXXXXXXXXXIINXXX</b>

fulfills all the relevant provisions of the following directive:

**Pressure Equipment Directive 2014/68/EU<sup>1</sup>**  
**Regulation (EC) n° 1935/2004**  
**Regulation (EC) n° 2023/2006**

and with the following harmonized standards and/or regulations:

**EN 12266-1:2012, EN 19:2016**

The technical file has been prepared by the signer of this document.

David Reyero Brunet  
Technical Office Manager  
15th December 2021



Document: 10.207.30.04EN  
Revision: (0) 2021/12

<sup>1</sup>DN≤25 Designed and manufactured in accordance with the sound engineering practice  
DN>25 Class I equipment. Conformity assessment procedure used: Module A

# Declaration of Conformity



**INOXPA S.A.U.**

Telers, 60  
17820 - Banyoles (Spain)

hereby declare under our sole responsibility that the

Machine:	<b>VALVE</b>
Model:	<b>OVERFLOW VALVE</b>
Type:	<b>74700</b>
Size:	<b>DN 25 - DN 80 / OD 1" - OD 3"</b>
Serial number:	<b>IXXXXXXXXXX to IXXXXXXXXXX XXXXXXXXXXIINXXX to XXXXXXXXXXXIINXXX</b>

fulfils all the relevant provisions of these regulations:

**Pressure Equipment (Safety) Regulations 2016<sup>1</sup>**

and with the following designated standards:

**EN 12266-1:2012, EN 19:2016**

The technical file has been prepared by the signer of this document.

David Reyero Brunet  
Technical Office Manager  
15th December 2021



Document: 10.207.30.05EN

Revision: (0) 2021/12

<sup>1</sup>DN≤25 Designed and manufactured in accordance with the sound engineering practice  
DN>25 Class I equipment. Conformity assessment procedure used: Module A

# 1. Safety

## 1.1. INSTRUCTION MANUAL.

This instruction manual contains basic indications which should be fulfilled during the installation, starting and maintenance. The information published in the instruction manual is based on updated information. INOXPA reserves the right to modify this instruction manual without prior notice.

## 1.2. START-UP INSTRUCTIONS.

This instruction manual contains essential useful information to handle and maintain your valve appropriately. Not only should the safety instructions indicated in this chapter be observed and fulfilled, but so should the special measures and recommendations included in the other chapters of this manual. These instructions should be kept in a safe location near the installation.

## 1.3. SAFETY.

### 1.3.1. Warning symbols.



**General danger of injury**



**Danger of injuries caused by the rotary parts of the equipment**



**Electrical hazard**



**Danger! Caustic or corrosive agents.**



**Danger! Suspended loads**



**Danger for the correct operation of the equipment.**



**Compulsory requirement to ensure safety at work**



**Use of goggles is compulsory.**

## 1.4. GENERAL SAFETY INSTRUCTIONS.



**Read the instruction manual carefully before installing and starting up the valve. Contact INOXPA in case of doubt**

### 1.4.1. During the installation.



The *Technical Specifications* of Chapter 8 should always be observed.

The installation and use of the valve should always be carried out in accordance with applicable regulations regarding health and safety.

Before starting up the valve, verify that the assembly is correct and that the shaft is perfectly aligned. An incorrect alignment and/or excessive force in securing the valve may cause serious mechanical problems in the valve.

### 1.4.2. During operation.



The *Technical Specifications* of Chapter 8 should always be observed. Under no circumstances can the limit values specified be exceeded.



**NEVER touch the valve and/or the tubes in contact with the liquid during operation. You risk being burnt if you work with hot products.**



The valve contains parts operating in linear movement. Do not place your hands or fingers in the valve-closing area. This may cause serious injury.

#### 1.4.3. During maintenance



The *Technical Specifications* of Chapter 8 should always be observed.

**NEVER** disassemble the valve until the pipes have been emptied. Bear in mind that the liquid in the pipe may be dangerous or extremely hot. Consult the regulations in effect in each country for these cases.

Do not leave parts loose on the floor.



All electrical work should be carried out by authorised personnel.

#### 1.4.4. In compliance with the instructions.

Any non-fulfilment of the instructions may result in a risk for the operators, the environment and the machine, and may result in the loss of your right to claim damages

This non-fulfilment may result in the following risks:

- Failure of important functions of the machines/plant.
- Failure of specific maintenance and repair procedures.
- Possibility of electric, mechanical and chemical risks.
- Will place the environment in danger due to the release of substances.

#### 1.5. GUARANTEE.

Any guarantee will be cancelled immediately and as a matter of law and, in addition, we will require compensation for any claims of civil liability presented by third parties, if:

- The installation and maintenance work has not been carried out according to the instructions of this manual.
- The repairs are not carried out by our personnel or have been carried out without our written authorisation.
- The parts used are not INOXPA original parts.
- Modifications have been carried out on our materials without written authorisation.
- The material has been badly used, incorrectly used, or used with negligence or has not been used according to the indications and intended use specified in this manual.

The general conditions of delivery already in your possession are also applicable.

Please do not hesitate to contact us in case of doubts or more complete explanations are required on specific data (adjustments, assembly, disassembly, etc.).

## 2. Table of contents

<b>1. Safety</b>	
1.1. Instruction manual.....	3
1.2. Start-up instructions.....	3
1.3. Safety.....	3
1.4. General safety instructions.....	3
1.5. Guarantee.....	4
<b>2. Table of contents</b>	
<b>3. Receiving and Installation</b>	
3.1. Check the shipment .....	6
3.2. Delivery and unpacking .....	6
3.3. Identification .....	6
3.4. Location.....	7
3.5. Flow direction.....	7
3.6. Overflow valve position. ....	7
3.7. Assembly. ....	7
3.8. Inspecting and checking .....	8
3.9. Welding.....	8
<b>4. Star-up</b>	
4.1. Valve applications.....	9
4.2. Start-up.....	9
4.3. Operation.....	9
4.4. Valve calibration.....	9
<b>5. Operating problems Causes and solutions</b>	
<b>6. Maintenance</b>	
6.1. General information .....	11
6.2. Maintenance.....	11
6.3. Cleaning.....	12
<b>7. Assembly and disassembly</b>	
7.1. Disassembly / assembly of the overflowvalve fig: 74700.....	13
7.2. Disassembly / assembly of the overflowvalve fig: 74700m.....	14
<b>8. Technical Specifications</b>	
8.1. Overflow valve dimensions.....	17
8.2. Section and parts list.....	18
8.3. Parts lists .....	20

# 3. Receiving and Installation

## 3.1. CHECK THE SHIPMENT

The first thing to do on receiving the valve is to verify that it matches the delivery note.

INOXPA will inspect all the equipment before packing, although it cannot guarantee that the merchandise will arrive intact to the user. For this reason, the valve received and any other article should be checked and, if it is found not to be in good condition and/or not all parts are included, the carrier should submit a report as soon as possible.

Each valve has a manufacturing number engraved. Indicate the manufacturing number in all documents and correspondence.

## 3.2. DELIVERY AND UNPACKING



**INOXPA will not be responsible for the inappropriate unpacking of the valve and its components.**

### 3.2.1. Delivery:

Check that all the parts indicated in the delivery slip exist

- Complete valve.
- Its components (if supplied).
- Delivery slip.
- Instruction manual.

### 3.2.2. Unpacking:

- Remove all traces of packing materials from the valve or parts.
- Inspect the valve or its constituent parts for possible damage caused during transport.
- Avoid any possible damage to the valve and its components.

## 3.3. IDENTIFICATION

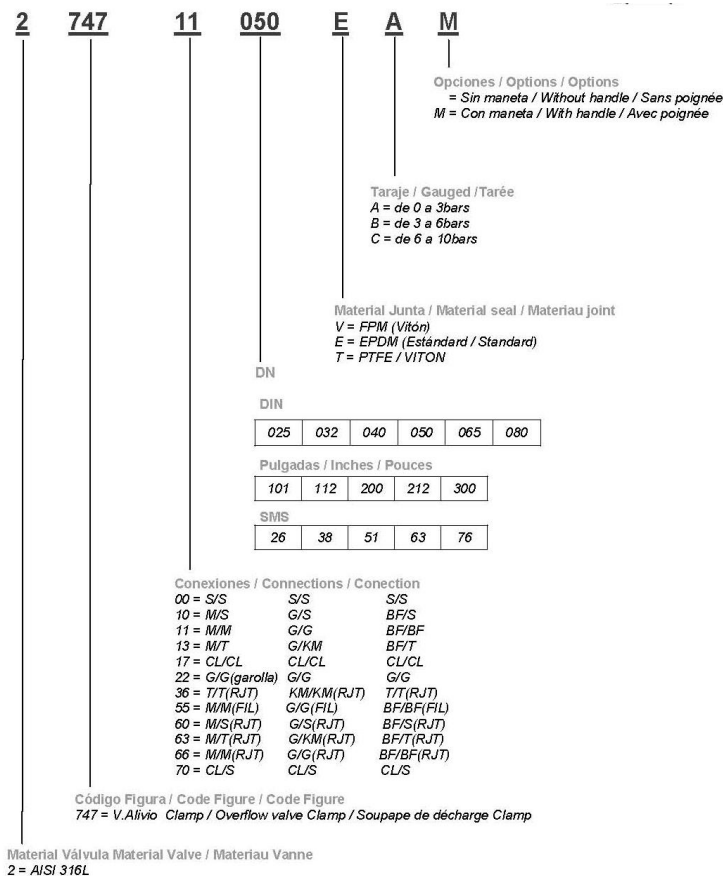



**The buyer or user will be responsible for the assembly, installation, starting and operation of the valve.**

### 3.4. LOCATION.

Place the valve in such a way as to facilitate inspections and checks. Leave sufficient space around the valve for appropriate inspection, separation and maintenance (See Section 3.7.1).

### 3.5. FLOW DIRECTION.

The overflow valve is designed to be installed according to the indicated direction of flow.

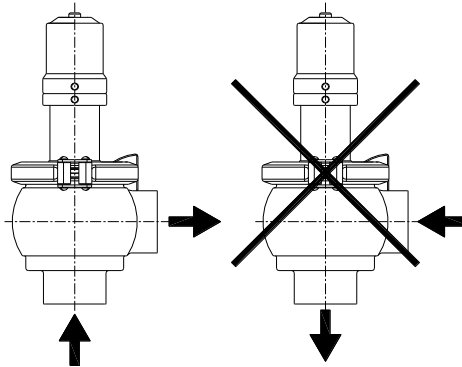

### 3.6. OVERFLOW VALVE POSITION.

The overflow valve is designed to be installed in any position, although fitting it upside down is not recommended.

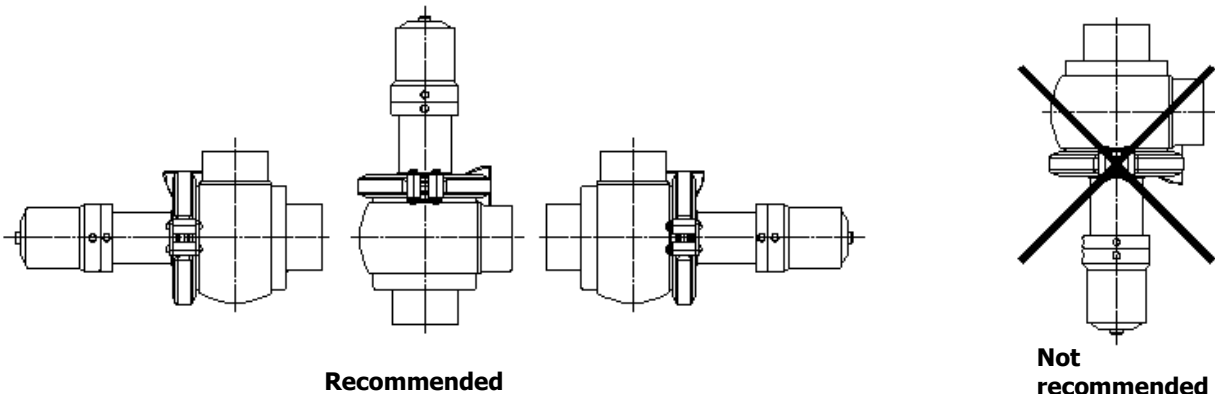

### 3.7. ASSEMBLY.

Once the location of the valve is established, the pipe can be connected by welding the body or by means of accessories (unions). The overflow valve is designed to be installed in any position, although fitting it upside down is not recommended.

Excessive stress should be avoided during the assembly of the valves and special attention should be given to the following:

- Vibration which may be produced in the installation.
- Expansion of the pipes during circulation of hot liquids.
- The weight that the pipes can withstand.
- Excessive intensity of welding.

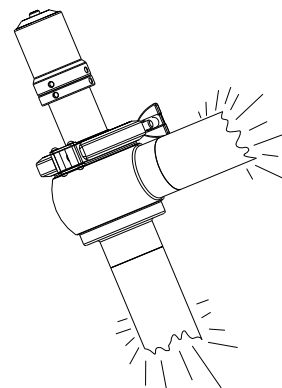



### 3.8. INSPECTING AND CHECKING

Check the following before use:

- Check that the clamp and the adjusting nuts are well tightened.
- If it has a handle, turn it several times to ensure that it works. (the seat of the valve must lift and fall)

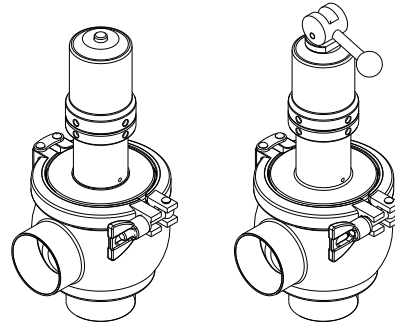

### 3.9. WELDING.



**The welding work can only be carried out by people qualified, trained and equipped with the necessary means to carry out this work.**

**Disassemble the valve before starting the welding work.**

#### 3.9.1. Welding end overflow valve . 74700

- Disassemble the valve as indicated in the *Assembly and disassembly* section.
- Weld the valve body to the pipes.
- When welding the valve body, it is very important to maintain the minimum distance (dimension A) enabling disassembly of the valve for later checks and replacement of internal valve parts (seals, shafts, springs). This distance is also important when the valves are supplied with a handle.

DN	A	
	No handle	With handle
25-1"	250	325
32	260	335
40-1 1/2"	275	345
50-2"	300	360
65-2 1/2"	355	425
80-3"	380	445

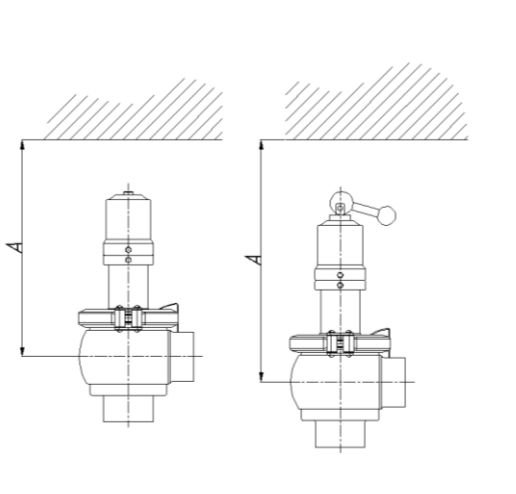

## 4. Star-up

The start-up of the valve can be carried out provided the instructions indicated in Chapter 3 – *Receiving and Installation* are followed.

### 4.1. VALVE APPLICATIONS.

This equipment is suitable for his use in food process.

Overflow valves of type 74700 and 74700M are basically used to avoid any excessive pressure in the pipes, particularly in positive-displacement pumps, in order to prevent any over-pressures that may damage the concerned equipment (bypass assembly).

### 4.2. START-UP.



**Before start-up, the responsible persons should be duly informed of the operation of the valve and the safety instructions to be followed. This instruction manual should be available to personnel at all times.**

The following should be taken into consideration before starting up the valve;

- Check that the pipe and valve are completely free from any traces of welding or other foreign matter. Carry out the cleaning of the system if required.
- Verify the smooth operation of the valve. If necessary, lubricate moving/rotating parts with special grease or soapy water.
- Check for possible leaks and check that all the pipes and connections are watertight and free from leaks
- Actuate the valve (if supplied with a handle)

### 4.3. OPERATION.



**Do not modify the operating parameters for which the valve has been designed without written prior authorisation from INOXPA.**



**Danger of burns! Do not touch the valve or pipes when hot liquids are circulating or when cleaning and/or sterilisation are being carried out.**

### 4.4. VALVE CALIBRATION.

The overflow valve can be shipped pre-calibrated in factory, provided this has been requested in writing on the order. Overflow valve calibration is carried out using a bypass-type assembly (flow recirculation). To carry out the calibration, it is necessary to use a pump, a gauge (for pressure measurements), a shut-off valve and the overflow valve.

Operate the pump with the shut-off valve in closed position. The flow will make the bypass (recirculation) by passing through the overflow valve. Tighten the upper nut (first loosening the lock nut) of the overflow valve until the gauge shows that the pump is at maximum working pressure. The overflow valve will remain calibrated to the pressure indicated on the gauge; if it exceeds this pressure, then the overflow valve will open and make the flow recirculate preventing the installation from being damaged.

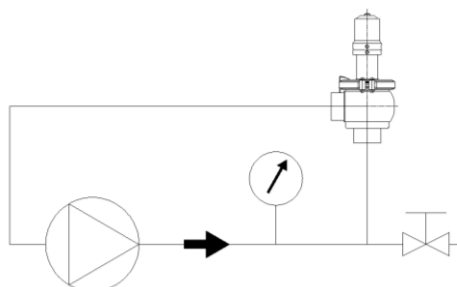

# 5. Operating problems. Causes and solutions

PROBLEM	CAUSE/EFFECT	SOLUTION
<b>VALVE DOES NOT CLOSE</b>	<p>Dirt / foreign matter between the seal of the shaft and the seat of the valve body.</p> <p>The springs are not applying pressure to the stop washer of the shaft</p> <p>The check valve seal is worn and defective.</p>	<ul style="list-style-type: none"> <li>• Clean the body and seat.</li> <li>• Increase the tightening torque of the springs.</li> <li>• Replace the seals.</li> </ul>
<b>INTERNAL LEAK OF THE PRODUCT (VALVE CLOSED)</b>	Premature wearing of the seals.	<ul style="list-style-type: none"> <li>• Replace the seals.</li> </ul>
	<p>Premature wearing of the seals.</p> <p>Watertight seal worn or affected by the product.</p> <p>Excessive pressure in the line.</p> <p>Working temperature too high</p> <p>Loss of watertightness (vibration).</p>	<ul style="list-style-type: none"> <li>• Replace the seals with others of different material and more appropriate to the product.</li> <li>• Tighten any loose components.</li> <li>• Clean frequently.</li> </ul>
	Backpressure	<ul style="list-style-type: none"> <li>• Replace the spring with a stronger one.</li> </ul>
<b>EXTERNAL LEAK OF THE PRODUCT</b>	<p>Seal of the body defective</p> <p>Seal of the shaft defective</p>	<ul style="list-style-type: none"> <li>• Replace the seals with new ones</li> </ul>
<b>VALVE DOES NOT OPEN/CLOSE</b>	<p>Deformation of seat seal.</p> <p>Spring in poor condition and/or jammed (dirtiness)</p> <p>The valve does not close when the pressure increases.</p>	<ul style="list-style-type: none"> <li>• Replace the seal seat with other of different quality, if prematurely deteriorated.</li> <li>• Replace spring and/or shaft (clean).</li> <li>• Adjust the valve</li> <li>• Recalibrate the valve. See point 4.4 Valve calibration.</li> </ul>

# 6. Maintenance

## 6.1. GENERAL INFORMATION

This valve, just like any other machine, requires maintenance. The instructions contained in this manual cover the identification and replacement of spare parts. The instructions have been prepared for maintenance personnel and for those responsible for the supply of spare parts.



Carefully read Chapter 8. *Technical Specifications*.

**All replaced material should be duly eliminated/recycled according to the directives in effect in the area.**

**Assembly and disassembly of the valves must only be carried out by qualified staff.**

**Before starting on maintenance work, ensure that the tubes are not pressurised.**

## 6.2. MAINTENANCE.

The following is recommended for appropriate maintenance:

- Regular inspection of the valve and its components.
- Keep a record of the operation of each valve, noting any incidents.
- Always have spare seals in stock.

During maintenance, pay particular attention to the danger indications indicated in this manual manual.



**The valve and pipes should not be pressurised during maintenance.**

**The valve should not be hot during maintenance. Danger of burns!.**

### 6.2.1. Maintenance of the seals.

REPLACEMENT OF SEALS	
<b>Preventive maintenance</b>	Replace after twelve (12) months.
<b>Maintenance after a leak</b>	Replace at the end of the process.
<b>Scheduled maintenance</b>	Regularly check that there are no leaks and that the valve is operating smoothly. Keep a record of the valve. Use statistics to plan inspections.
<b>Lubrication</b>	During assembly, apply lubricants compatible with the seal material. See the following table.

SEAL COMPONENT	LUBRICANT	Class NLGI DIN 51818
NBR/ FPM/ VMQ	Klübersynth UH 1 64-2403	3
EPDM/ NBR/ FPM	PARALIQ GTE 703	3

The time interval between each preventive maintenance may vary according to the working conditions to which the valve is submitted: Temperature, pressure, number of operations per day, type of cleaning solutions used, etc.

### 6.2.2. Storage

Storage of the valves should be carried out in an enclosed area, under the following conditions:

Temperature from 15°C to 30°C  
Relative humidity <60%

Open-air storage of the equipment is NOT allowed.

### 6.2.3. Spare parts

To request spare parts, it is necessary to indicate the type of valve, the position and the description of the part which can be found in chapter 8. *Technical Specifications*.

## 6.3. CLEANING



**The use of aggressive cleaning products such as caustic soda and nitric acid may cause burns to the skin.**

**Use rubber gloves during the cleaning process.**



**Always use protective goggles.**

### 6.3.1. Automatic CIP (cleaning-in-place)

If the valve is installed in a system provided with the CIP process, its disassembly will not be required.

Cleaning solutions for CIP processes.

Only use clear water (chlorine-free) to mix with the cleaning agents:

**a) Alkaline solutions:** 1% by weight of caustic soda (NaOH) at 70°C (150°F)

1 Kg NaOH + 100 l. of water = cleaning solution

o

2,2 l. NaOH at 33% + 100 l. of water = cleaning solution

**b) Acid solution:** 0,5% by weight of nitric acid (HNO<sub>3</sub>) at 70°C (150°F)

0,7 litres HNO<sub>3</sub> at 53% + 100 l. of water = cleaning solution



**Check the concentration of cleaning solutions; it may cause the deterioration of the watertight seals of the valve.**

To eliminate any remains of cleaning products, ALWAYS perform a final rinse with clean water on completion of the cleaning process.



**Before beginning the disassembly and assembly work, clean the valve inside as well as outside.**

### 6.3.2. Automatic SIP (sterilization-in-place)

The process of sterilization with steam is applied to all the equipment including the pigging.



**Do NOT start the equipment during the process of sterilization with steam. The parts/materials suffer no damage if the indications specified in this manual are observed.**

**No cold liquid can enter the equipment till the temperature of the equipment is lower than 60°C (140°F).**

#### **Maximum conditions during the SIP process with steam or overheated water**

- |    |                          |  |
|----|--------------------------|--|
| a) | <b>Max. temperature:</b> | 140°C / 284°F  |
| b) | <b>Max. time:</b>        | 30 min   |
| c) | <b>Cooling:</b>          | Sterile air or inert gas                                       |
| d) | <b>Materials:</b>        | EPDM / PTFE (recommended)<br>FPM / NBR / VMQ (not recommended) |

# 7. Assembly and disassembly



Proceed with caution. There is danger of personal injury.

Assembly and disassembly of the valves must only be carried out by qualified staff.



**Caution! Recoiled springs.**

There is danger of injury if the valve clamp is released (pos. 34) while the valve is still at rest. The recoiled springs may abruptly throw the regulating nut upwards (pos. 26C) .

It is essential to release the tension in the springs before loosening the clamp.

## 7.1. DISASSEMBLY / ASSEMBLY OF THE OVERFLOWVALVE FIG: 74700

### Disassembly

1. Loosen the lock nut (26F).
2. Mark the position in the shaft (08) and then unscrew and release the valve nut (26C).
3. Remove the clamp (34).
4. Remove the spring cover (12A). The shaft stop washer (25) and the spring (06) will be pulled out.
5. Pull the shaft (08) upwards together with the body cap (12), shaft seal (05) and the O-ring (20B).
6. Remove the shaft seal (05) from the body cap (12).
7. Remove the O-ring (20B) from the body cap (12).
8. Remove the elastic ring (45) and the shaft seal (08A).
9. Remove the seat seal (19).

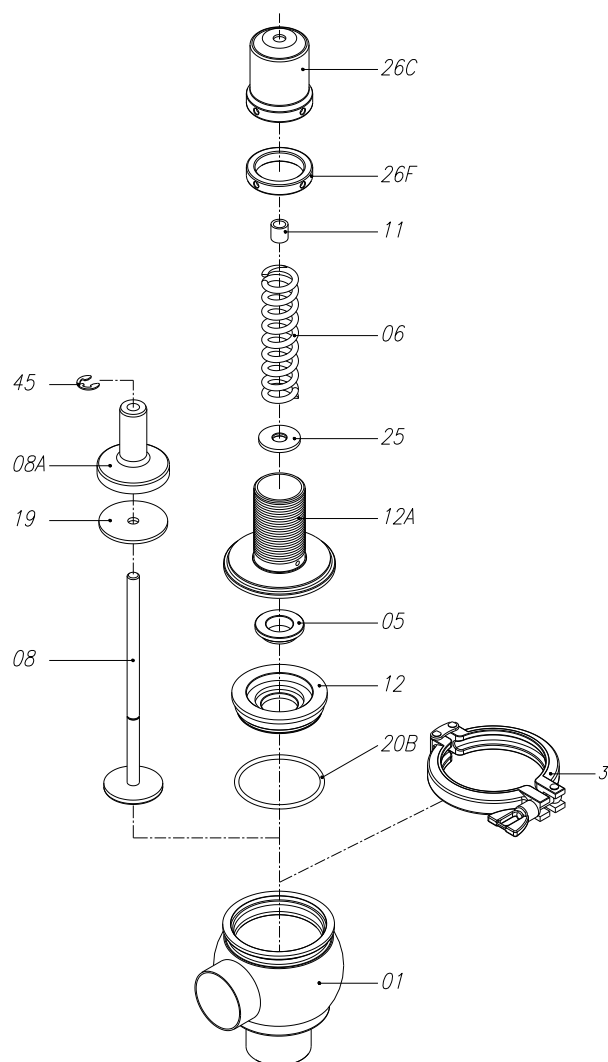

### Assembly

1. Place the seat seal (19) on the shaft (08).
2. Place the shaft seal (08A) and attach the assembly with the elastic ring (45).
3. Place the O-ring (20B) on the body cap (12).
4. Place the shaft seal (05) in the body cap (12).
5. Place the shaft assembly through the shaft seal (05) and onto the body (01).
6. Mount the spring cover (12A) on the valve body (01).
7. Assemble the spring cover (12A) to the valve housing (01) with the clamp (34). Tighten the nut of the clamp.
8. Place the stop washer (25) and the springs (06) on the spring cover (12A).
9. Screw the lock nut on (26F) passing the mark made before disassembly.
10. Screw the nut on (26C) until reaching the mark.
11. Screw the lock nut (26F) against the nut (26C) to fix it in place.



A spanner is required to disassemble the valve.

## 7.2. DISASSEMBLY / ASSEMBLY OF THE OVERFLOWVALVE FIG: 74700M.

### Disassembly

1. Remove pin (50A) from the handle (04).
2. Remove the handle (04) from the shaft (08).
3. Loosen the lock nut (26F).
  10. Mark the position in the shaft (08) and then unscrew and release the valve nut (26C).
  11. Remove the clamp (34).
  12. Remove the spring cover (12A). The shaft stop washer (25) and the spring (06) will be pulled out.
  13. Pull the shaft (08) upwards together with the body cap (12), seat seal (05) and the O-ring (20B).
  14. Remove the seat seal I (05) from the body cap (12).
  15. Remove the O-ring (20B) from the body cap (12).
  16. Remove the elastic ring (45) and the shaft sleeve (08A).
  17. Remove the seat seal (19).

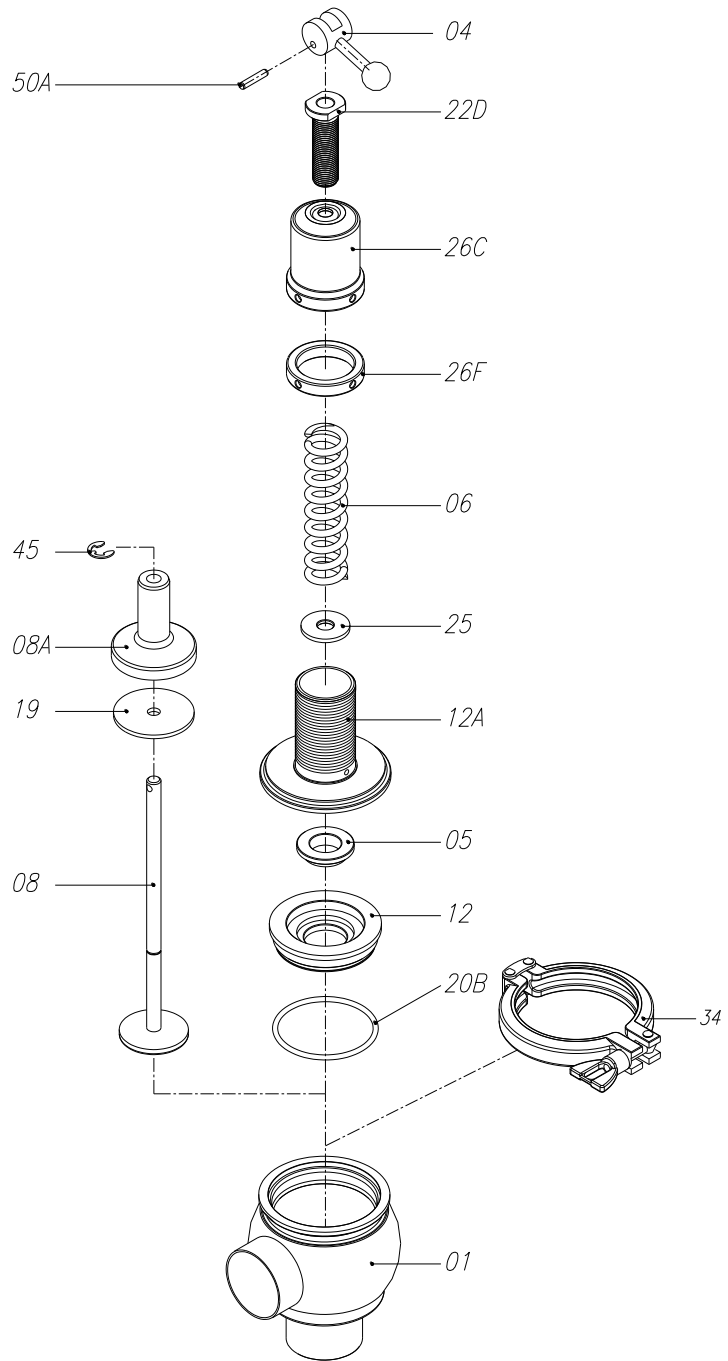

### Assembly

1. Mount the seat seal (19) on the shaft (08).
2. Mount the shaft sleeve (08A) and attach the assembly with the elastic ring (45).
3. Place the O-ring (20B) on the body cap (12).
4. Place the seat seal (05) in the body cap (12).
5. Mount the shaft assembly over the seat seal (05) and place onto the body (01).
6. Mount the spring cover (12A) on the valve body (01).
7. Assemble the spring cover (12A) to the valve housing (01) with the clamp (34). Tighten the nut of the clamp.
8. Place the spring washer (25) and the springs (06) on the body cap (12A).
9. Screw the lock nut on (26F) passing the mark made before disassembly.
10. Screw the nut on (26C) until reaching the mark.
11. Screw the lock nut (26F) against the nut (26C) to fix it in place.
12. Place the handle (04) on the shaft (08) ensuring that the holes are lined up.
13. Insert the pin (50A) into the hole of the handle (04) and the shaft (08).



**A spanner is required to disassemble the valve.**

### 7.3. DISASSEMBLY / ASSEMBLY OF THE OVERFLOWVALVE WITH PTFE SEAT.

#### Disassembly

1. Loosen the lock nut (26F).
2. Mark the position in the shaft (08) and then unscrew and release the valve nut (26C).
3. Remove the clamp (34).
4. Remove the spring cover (12A). The shaft stop washer (25) and the spring (06) will be pulled out.
5. Pull the shaft (08) upwards together with the body cap (12), shaft seal (05) and the O-ring (20B).
6. Remove the shaft seal (05) from the body cap (12).
7. Remove the O-ring (20B) from the body cap (12).
8. Remove the elastic ring (45) and the shaft seal (08A).
9. Remove the O-ring (20C) to the shaft seal (08A).
10. Remove the seat seal (19).

#### Assembly

1. Place the seat seal (19) on the shaft (08) and the O-ring (20C) in the shaft seal (08A).
2. Place the shaft seal (08A) and attach the assembly with the elastic ring (45).
3. Place the O-ring (20B) on the body cap (12).
4. Place the shaft seal (05) in the body cap (12).
5. Place the shaft assembly through the shaft seal (05) and onto the body (01).
6. Mount the spring cover (12A) on the valve body (01).
7. Assemble the spring cover (12A) to the valve housing (01) with the clamp (34). Tighten the nut of the clamp.
8. Place the stop washer (25) and the springs (06) on the spring cover (12A).
9. Screw the lock nut on (26F) passing the mark made before disassembly.
10. Screw the nut on (26C) until reaching the mark.
11. Screw the lock nut (26F) against the nut (26C) to fix it in place.

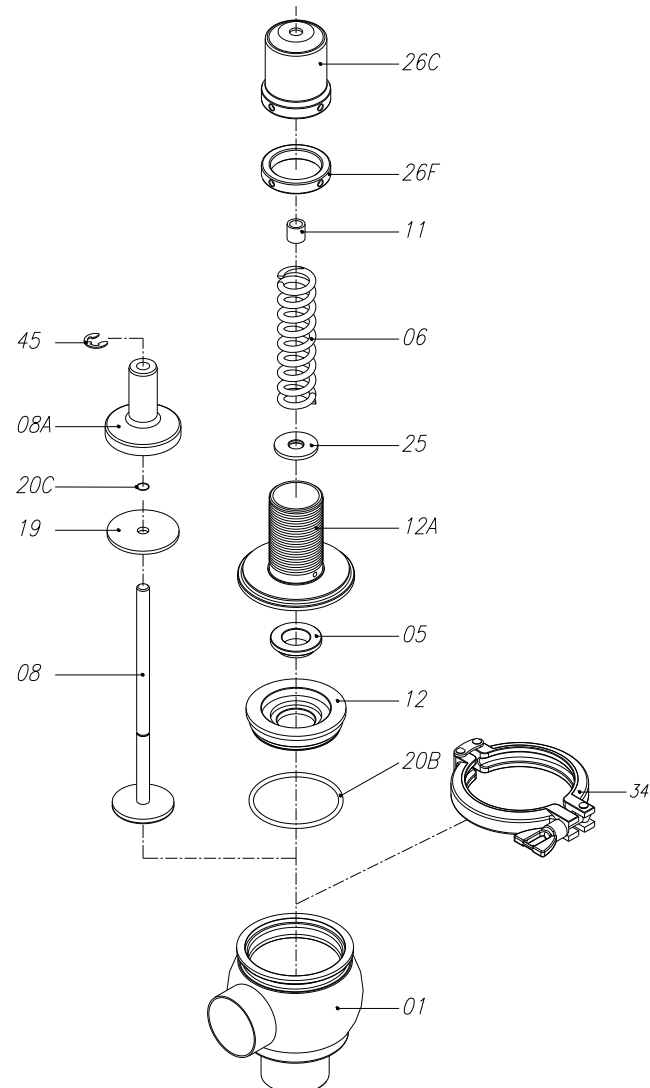

**A spanner is required to disassemble the valve.**



## 8. Technical Specifications

VALVE GENERAL DATA						
Maximum working pressure	DN-25/80 DN-1"/3" 10 bar					
Maximum working temperature	121°C (250°F) EPDM standard seals (Other qualities of seals will be adapted for higher temperatures)					
Opening pressure	Spring-adjustable.					
Surface finish	In contact with the product: Ra ≤ 0,8 μm External surfaces: Machined finish (turned on lathe)					
Maximum output	DN-25/1"	DN-32	DN-40/1½"	DN-50/2"	DN-65/2½"	DN-80/3"
	10000lts/h	12000lts/h	15000lts/h	20000lts/h	35000lts/h	55000lts/h

VALVE MATERIALS	
Parts in contact with the product	AISI 316L (1.4404)
Other steel parts	AISI 304L (1.4306)
Seals in contact with the product	EPDM (Estándar) – VITON - PTFE
Acabado superficial	Parts in contact with the product < Ra. 0,8μm
Tipo de conexiones	DIN 11851 (Standard) Connections: Weld, FIL-IDF, BS-RJT, SMS, Clamp, Flanges, Macon



**Resistance of the materials / seals depends on the type of pumped product and processing conditions. Please contact INOXPA for help in making the right choice.**

### 8.1. OVERFLOW VALVE DIMENSIONS

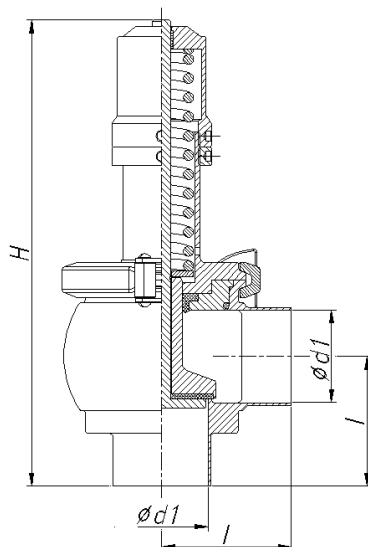

S/S Fig 74700

DN	d1	I	H	AISI 316L
1"	22,1	50	220	274700101EB
1 1/2"	34,8	60	240	274700112EB
2"	47,5	70	255	274700200EB
2 1/2"	60,2	80	290	274700212EB
3"	72,9	90	310	274700300EB

DN	d1	I	H	AISI 316L
25	26	50	220	274700025EB
32	32	55	230	274700032EB
40	38	60	240	274700040EB
50	50	70	255	274700050EB
65	66	80	290	274700065EB
80	81	90	310	274700080EB

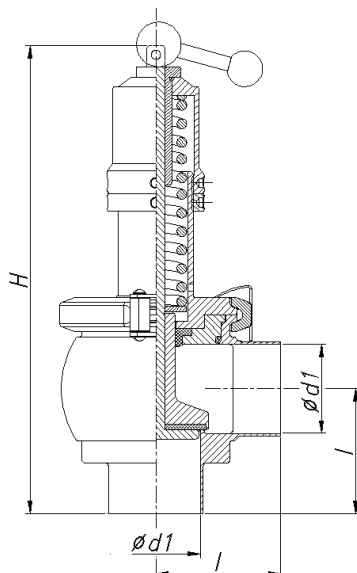

S/S Fig 74700M

DN	d1	I	H1	AISI 316L
1"	22,1	50	230	274700101EAM
1 1/2"	34,8	60	250	274700112EAM
2"	47,5	70	265	274700200EAM
2 1/2"	60,2	80	305	274700212EAM
3"	72,9	90	325	274700300EAM

DN	d1	I	H1	AISI 316L
25	26	50	230	274700025EAM
32	32	55	240	274700032EAM
40	38	60	250	274700040EAM
50	50	70	265	274700050EAM
65	66	80	305	274700065EAM
80	81	90	325	274700080EBAM

## 8.2. SECTION AND PARTS LIST

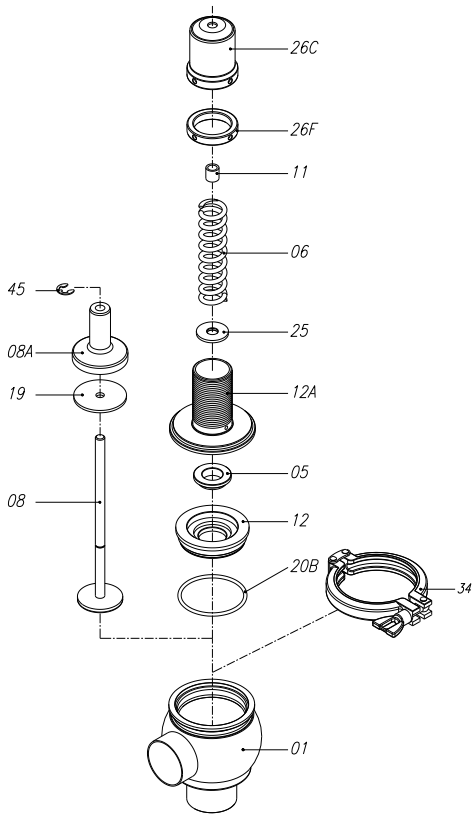

**FIG:74700**

POSITION	DESIGNATION	MATERIAL	QUANTITY
01	Housing	AISI 316L	1
05*	Shaft seal	EPDM	1
06	Spring	AISI 302	1
08	Shaft	AISI 316L	1
08A	Shaft sleeve	AISI 316L	1
11*	Guide bushing	Igildur G	1
12	Body cap	AISI 316L	1
12A	Spring cover	AISI 304L	1
19*	Gasket	EPDM	1
20B*	O'ring	EPDM	1
25	Spring washer	AISI 304L	1
26C	Nut	AISI 304L	1
26F	Lock nut	AISI 304L	1
34	Clamp	AISI 304	1
45	Elastic ring	AISI 304	1

\* Recommended spare parts.

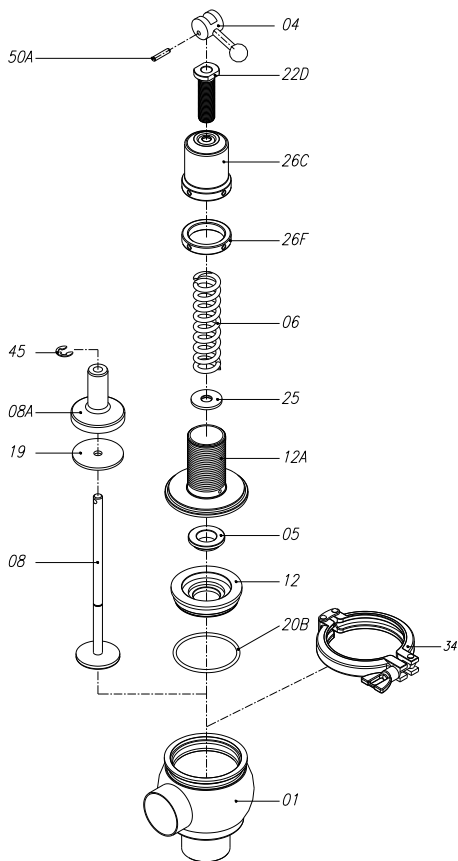

**FIG:74700M**

POSITION	DESIGNATION	MATERIAL	QUANTITY
01	Housing	AISI 316L	1
04	Handle	AISI 304L	1
05*	Shaft seal	EPDM	1
06	Spring	AISI 302	1
08	Shaft	AISI 316L	1
08A	Shaft sleeve	AISI 316L	1
12	Body cap	AISI 316L	1
12A	Spring cover	AISI 304L	1
19*	Gasket	EPDM	1
20B*	O-ring	EPDM	1
22D	Upper screw	BRONCE	1
25	Spring washer	AISI 304L	1
26C	Nut	AISI 304L	1
26F	Lock nut	AISI 304L	1
34	Clamp	AISI 304	1
45	Elastic ring	AISI 304	1
50A	Pin	AISI 304	1



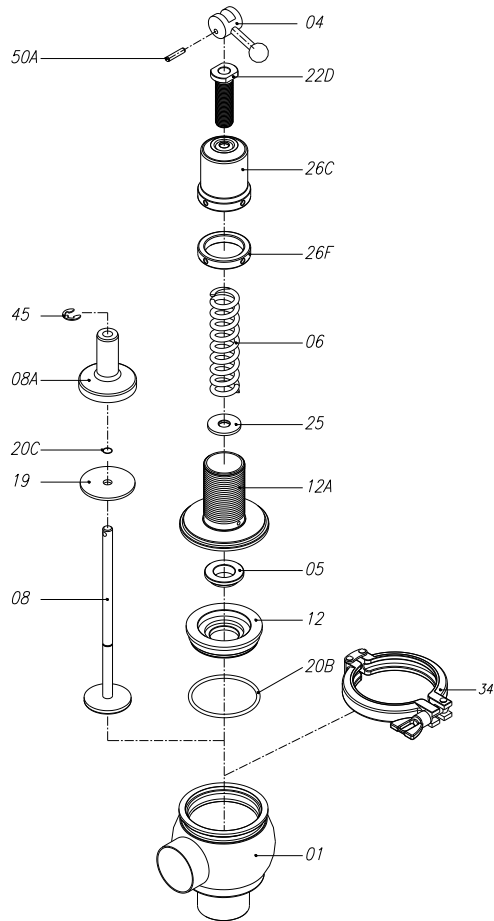

\* Recommended spare parts.



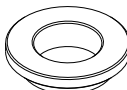

POSITION	DESIGNATION	MATERIAL	QUANTITY
01	Housing	AISI 316L	1
05*	Shaft seal	FPM	1
06	Spring	AISI 302	1
08	Shaft	AISI 316L	1
08A	Shaft sleeve	AISI 316L	1
11*	Guide bushing	Iglidur G	1
12	Body cap	AISI 316L	1
12A	Spring cover	AISI 304L	1
19*	Gasket	PTFE	1
20B*	O'ring	FPM	1
20C*	O'ring	FPM	1
25	Spring washer	AISI 304L	1
26C	Nut	AISI 304L	1
26F	Lock nut	AISI 304L	1
34	Clamp	AISI 304	1
45	Elastic ring	AISI 304	1

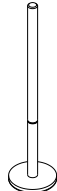
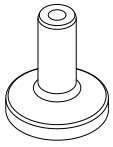
\* Recommended spare parts

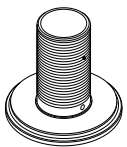
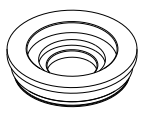

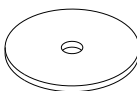
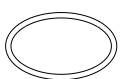
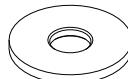
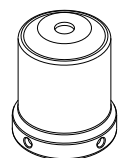

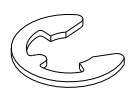
**8.3. PARTS LIST**  
**FIG:74700**





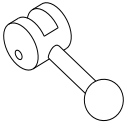

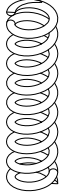

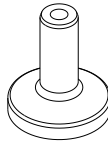
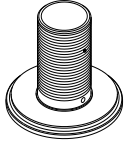
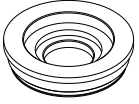
DN	01	05*	06	08	08A	11*	12A	12
								
25	351249.6	450811.E	1-MU-452447	452301A.6	452123A.6	GSM1012-10	452210.4	450890.6
1"	351256.6		2-MU-452448	452618A.6	452617A.6			
			3-MU-452599					
32	351250.6		1-MU-452449	452301B.6	452123B.6			
			2-MU-452450					
			3-MU-452600					
40	351251.6		1-MU-452451	452301C.6	452123C.6	GSM1315-10	452213.4	450893.6
1 1/2"	351257.6		2-MU-452452	452618C.6	452617C.6			
			3-MU-452601					
50	351252.6		1-MU-452453	452301D.6	452123D.6			
2"	351258.6		2-MU-452454	452618D.6	452617D.6			
			3-MU-452602					
65	351253.6	1-MU-452455	452301E.6	452123E.6	GSM1315-10	452214.4	450894.6	
2 1/2"	351259.6	2-MU-452456	452618E.6	452617E.6				
		3-MU-452603						
3"	351260.6	1-MU-452457	452618F.6	452617F.6				
		2-MU-452458	452301F.6	452123F.6				
80	351254.6	3-MU-452637						

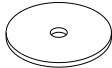
DN	19*	20B*	25	26C	26F	34	45
							
25	452121A.E	O4040835	452119A	452138.4	452137.4	1703200	AE-09000
1"	452616A.E						
32	452123B.E						
40	452121C.E	O4053535	452119B	452115.4	452117.4	1703212	
1 1/2"	452616C.E						
50	452121D.E						
2"	452616D.E	O4066235				1703300	
65	452121E.E	O4091635	452119C	452116.4	452118.4	1703400	
2 1/2"	452616E.E						
3"	452616F.E						
80	452121F.E	O4098035				1703412	

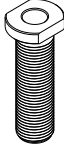
\* Recommended spare parts.

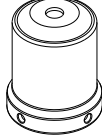
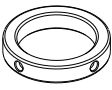
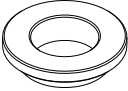
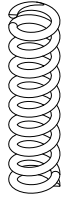
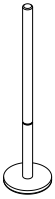
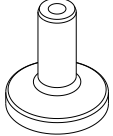

**FIG:74700M**





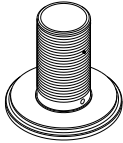
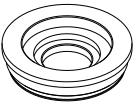

DN	01	04	05*	06	08	08A	12A	12
								
25	351249.6	C-45082A.4	450811.E	1-MU-452448	452302A.6	452123A.6	452210.4	450890.6
1"	351256.6			2-MU-452599	452619A.6	452617A.6		
32	351250.6			1-MU-452450	452302B.6	452123B.6		
40	351251.6			2-MU-452600	452619C.6	452617C.6	452211.4	450891.6
1 1/2"	351257.6			1-MU-452452	452302C.6	452123C.6		
50	351252.6			2-MU-452601	452619D.6	452617D.6	452212.4	450892.6
2"	351258.6	1-MU-452454		452302D.6	452123D.6			
65	351253.6	C-45082B.4		2-MU-452602	452619E.6	452617E.6	452213.4	450893.6
2 1/2"	351259.6			1-MU-452456	452302E.6	452123E.6		
3"	351260.6			2-MU-452603	452619F.6	452617F.6	452214.4	450894.6
80	351254.6			1-MU-452458	452302F.6	452123F.6		

DN	19*	20B*	22D	25	26C	26F	34	45	50A
									
25	452121A.E	O4040835	452127.Z	452119A	452139.4	452137.4	1703200	AE-09000	PA-0524
1"	452616A.E								
32	452123B.E								
40	452121C.E	O4053535		452119B	452125.4	452117.4	1703212		
1 1/2"	452616C.E								
50	452121D.E	O4066235		452128.Z	452119C	452126.4	452118.4		
2"	452616D.E								
65	452121E.E	O4091635	1703400						
2 1/2"	452616E.E								
3"	452616F.E	O4098035	1703412						
80	452121F.E								

\* Recommended spare parts.

**FIG:74700 PTFE seat**

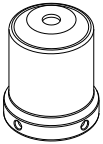
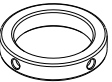
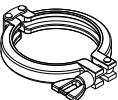
DN	01	05*	06	08	08A	11*	12A	12
								
25	351249.6	450811.E	1-MU-452447 2-MU-452448	452301A.6	452123A.6	GSM1012-10	452210.4	450890.6
1"	351256.6		3-MU-452599	452618A.6	452617A.6			
32	351250.6		1-MU-452449 2-MU-452450	452301B.6	452123B.6			
40	351251.6		1-MU-452451 2-MU-452452	452301C.6	452123C.6			
1 1/2"	351257.6		3-MU-452601	452618C.6	452617C.6			
50	351252.6		1-MU-452453 2-MU-452454	452301D.6	452123D.6			
2"	351258.6		3-MU-452602	452618D.6	452617D.6			
65	351253.6		1-MU-452455 2-MU-452456	452301E.6	452123E.6			
2 1/2"	351259.6		3-MU-452603	452618E.6	452617E.6			
3"	351260.6		1-MU-452457 2-MU-452458	452618F.6	452617F.6			
80	351254.6	3-MU-452637	452301F.6	452123F.6	GSM1315-10	452213.4	450893.6	
							452212.4	450892.6
							452214.4	450894.6

DN	19*	20B*	20C*	25	26C	26F	34	45
								
25	452960A.I	O2040835	O2009025	452119A	452139.4	452137.4	1703200	AE-09000
1"	452879A.I							
32	452960B.I							
40	452960C.I	O2053535	452119B	452125.4	452117.4	1703212		
1 1/2"	452879B.I							
50	452960D.I	O2066235	452119C	452126.4	452118.4	1703300		
2"	452879C.I							
65	452960E.I	O2091635	O2012030	452119C	452126.4	452118.4	1703400	
2 1/2"	452879D.I							
3"	452879D.I	O2101235	O2012030	452119C	452126.4	452118.4	1703412	
80	452960F.I							

\* Recommended spare parts.

**INOXPA, S.A.**

c/ Telers, 54 – PO Box 174  
17820 BANYOLES (GIRONA)  
Tel: 34 972575200  
Fax: 34 972575502  
e-mail: inoxpa@inoxpa.com  
www.inoxpa.com

**DELEGACIÓN LEVANTE**

PATERNA (VALENCIA)  
Tel: 963 170 101  
Fax: 963 777 539  
e-mail: inoxpa.levante@inoxpa.com

**LA CISTÉRNIGA (VALLADOLID)**

Tel: 983 403 197  
Fax: 983 402 640  
e-mail: sta.valladolid@inoxpa.com

**INOXPA SOLUTIONS LEVANTE**

PATERNA (VALENCIA)  
Tel: 963 170 101  
Fax: 963 777 539  
e-mail: isf@inoxpa.com

**ST. SEBASTIEN sur LOIRE**

Tel/Fax: 33 130289100  
e-mail: inoxpa.fr@inoxpa.com

**INOXPA ALGERIE**

ROUIBA  
Tel: 213 21856363 / 21851780  
Fax: 213 21854431  
e-mail: inoxpalgerie@inoxpa.com

**INOXPA UK LTD**

SURREY  
Tel: 44 1737 378 060 / 079  
Fax: 44 1737 766 539  
e-mail: inoxpa-uk@inoxpa.com

**INOXPA SKANDINAVIEN A/S**

HORSENS (DENMARK)  
Tel: 45 76 286 900  
Fax: 45 76 286 909  
e-mail: inoxpa.dk@inoxpa.com

**INOXPA SPECIAL PROCESSING  
EQUIPMENT, CO., LTD.**

JIAXING (China)  
Tel.: 86 573 83 570 035 / 036  
Fax: 86 573 83 570 038

**INOXPA WINE SOLUTIONS**

VENDARGUES (FRANCE)  
Tel: 33 971 515 447  
Fax: 33 467 568 745  
e-mail: frigail.fr@inoxpa.com /  
npourtaud.fr@inoxpa.com

**DELEGACIÓN NORD-ESTE /**

BARBERÀ DEL VALLÈS (BCN)  
Tel: 937 297 280  
Fax: 937 296 220  
e-mail: inoxpa.nordeste@inoxpa.com

**DELEGACIÓN CENTRO**

ARGANDA DEL REY (MADRID)  
Tel: 918 716 084  
Fax: 918 703 641  
e-mail: inoxpa.centro@inoxpa.com

**LOGROÑO**

Tel: 941 228 622  
Fax: 941 204 290  
e-mail: sta.rioja@inoxpa.com

**INOXPA SOLUTIONS FRANCE**

GLEIZE  
Tel: 33 474627100  
Fax: 33 474627101  
e-mail: inoxpa.fr@inoxpa.com

**WAMBRECHIES**

Tel: 33 320631000  
Fax: 33 320631001  
e-mail: inoxpa.nord.fr@inoxpa.com

**INOXPA SOUTH AFRICA (PTY) LTD**

JOHANNESBURG  
Tel: 27 117 945 223  
Fax: 27 866 807 756  
e-mail: sales@inoxpa.com

**S.T.A. PORTUGUESA LDA**

VALE DE CAMBRA  
Tel: 351 256 472 722  
Fax: 351 256 425 697  
e-mail: comercial.pt@inoxpa.com

**IMPROVED SOLUTIONS**

VALE DE CAMBRA  
Tel: 351 256 472 140 / 138  
Fax: 351 256 472 130  
e-mail: isp.pt@inoxpa.com

**INOXRUS**

MOSCOW (RUSIA)  
Tel / Fax: 74 956 606 020  
e-mail: moscow@inoxpa.com

**INOXPA UCRANIA**

KIEV  
Tel: 38 050 720 8692  
e-mail: kiev@inoxpa.com

**ZARAGOZA**

Tel: 976 591 942  
Fax: 976 591 473  
e-mail: inoxpa.aragon@inoxpa.com

**DELEGACIÓN STA**

GALDACANO (BILBAO)  
Tel: 944 572 058  
Fax: 944 571 806  
e-mail: sta@inoxpa.com

**DELEGACIÓN SUR**

JEREZ DE LA FRONTERA (CÁDIZ)  
Tel / Fax: 956 140 193  
e-mail: inoxpa.sur@inoxpa.com

**CHAMBLY (PARIS)**

Tel: 33 130289100  
Fax: 33 130289101  
e-mail: isf@inoxpa.com

**INOXPA AUSTRALIA PTY (LTD)**

MORNINGTON (VICTORIA)  
Tel: 61 3 5976 8881  
Fax: 61 3 5976 8882  
e-mail: inoxpa.au@inoxpa.com

**INOXPA USA, Inc**

SANTA ROSA  
Tel: 1 7075 853 900  
Fax: 1 7075 853 908  
e-mail: inoxpa.us@inoxpa.com

**INOXPA ITALIA, S.R.L.**

BALLO DI MIRANO – VENEZIA  
Tel: 39 041 411 236  
Fax: 39 041 5128 414  
e-mail: inoxpa.it@inoxpa.com

**INOXPA INDIA PVT. LTD.**

Maharashtra, INDIA.  
Tel: 91 2065 008 458  
inoxpa.in@inoxpa.com

**SAINT PETERSBURG (RUSIA)**

Tel: 78 126 221 626 / 927  
Fax: 78 126 221 926  
e-mail: spb@inoxpa.com

In addition to our branch offices, INOXPA operates with an independent distributor network which encompasses a total of more than 50 countries throughout the world. For more information, please, consult our web page: [www.inoxpa.com](http://www.inoxpa.com)  
This information is for guidance only. We reserve the right to modify any material or feature without notice in advance.