



INSTALLATION, SERVICE AND MAINTENANCE INSTRUCTIONS

ANNEX FOR EC ATEX CERTIFIED EQUIPMENT REGULATION 2014/34/EU

MIXER M-226 Ex

The contents of this Annex complements the information included in the instruction manual. You must always take into account the additional instructions in this annex for equipment registered under regulation 2014/34/EU.

This Annex is to be added to the manuals of the ATEX registered components that form part of the assembly (e.g. motors, etc.).

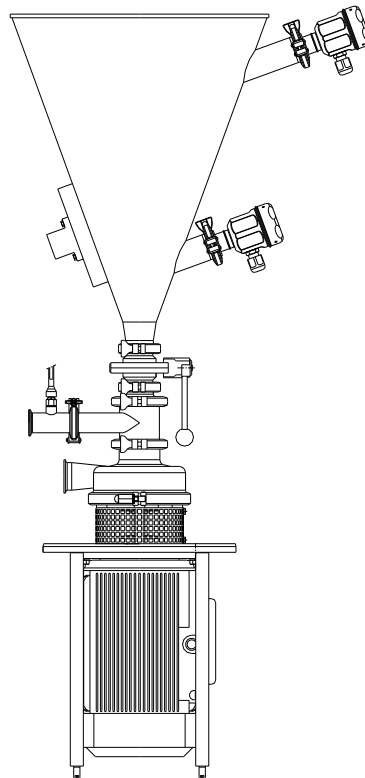

EU Declaration of Conformity

We,

INOXPA, S.A.U.

Telers, 60
17820 – Banyoles (Girona)

Hereby declare under our sole responsibility that the machine

BLENDER

Designation

M-226

From serial number **IXXXXXXXXXX** to **IXXXXXXXXXX** ⁽¹⁾

Is in compliance with applicable provisions of the following directive:

Directive ATEX 2014/34/EU

Applicable harmonized standards:

EN ISO 80079-36:2016

EN ISO 80079-37:2016

EN 1127-1:2019

EN 13237:2012

EN15198:2007

EN IEC 60079-0:2018

This Declaration of Conformity covers equipment with the following ATEX marking:

 II 2G Ex h IIB T4...T3 Gb

 II 2D Ex h IIIB T125 °C...T200 °C Db

 II 2G Ex h IIB T4...T3 Gb
II 2D Ex h IIIB T125 °C...T200 °C Db

The technical documentation referenced 020218/18 is on file with the notified body INERIS, Parc Technologique Alata BP 2 F-60550, Verneuil-en-Halatte, France. Reference num. 0080.

The person authorized to compile the technical documentation is the signer of this document.

Banyoles, 2022



David Reyero Brunet
Technical Office Manager

⁽¹⁾ Where X is a numeric character

1. Safety

1.1. INSTRUCTIONS MANUAL

1.2. START-UP INSTRUCTIONS

This annex to the instruction manual contains the basic instructions to be applied when installing, starting up and maintaining. It is therefore essential that the installer and responsible technical staff read said instructions manual before assembly. The manual must be available at all times near the pump or corresponding installation.

The safety indications explained in detail in this chapter as well as the special measures and additional recommendations in this annex chapter must be applied or observed.

1.3. SAFETY

1.3.1. Warning symbols

The safety symbols set out in this manual are represented by the following symbols; failure to comply therewith could endanger people or the machine and its operation:



This symbol identifies the annex safety instructions related with the risk of forming explosive atmospheres, and of creating ignition sources for explosive atmospheres, which could endanger your safety if said instructions are not observed.

1.4. GENERAL SAFETY INSTRUCTIONS

1.4.1. During installation

In order to reduce the risk derived from static electricity, it is necessary to earth the assembly so as to guarantee electrical continuity between the piping and the mixer

1.4.2. During operation

The threshold values for working conditions in explosive atmospheres must not be exceeded

The mixer has been selected based on the working conditions indicated by the user. INOXPA shall not be liable for any damage that may be derived from using the mixer in conditions different to those specified in the order, nor in those specified in the ATEX Form (F-O-PED-01)

1.4.3. During maintenance



Danger! Important instructions for protection from explosions.

When disassembling the mixer, an explosive atmosphere may be produced. It is therefore necessary to set up maximum-safety work authorisations. Furthermore, only staff qualified and trained for this purpose may take charge of such tasks

1.4.4. Conformity with the instructions

Any non-fulfilment of the instructions may result in a risk for the operators, the environment, the machine, and the installations, and may result in the loss of your right to claim damages.

This failure to comply may create the following risks (in addition to those already indicated in the manual):

- Creation of explosive atmospheres and the risk of explosion.

1.4.5. Guarantee

Any guarantee will be cancelled immediately and as a matter of law and, in addition, INOXPA will require compensation for any claims of civil liability presented by third parties, in case (in addition to the conditions already indicated in the manual):

- the equipment has been used incorrectly or has not been used according to the working conditions of the classified area, has been used in another classified area, in different conditions of temperature and pressure and/or substance.

2. Table of Contents

The indications in said paragraphs must be taken into account in addition to the whole mixer manual.

1. Safety	
1.1. INSTRUCTIONS Manual	1
1.2. Start-up instructions.....	1
1.3. SAFETY.....	1
1.4. GENERAL SAFETY INSTRUCTIONS	1
2. Table of Contents	
3. General Information	
3.1. DESCRIPTION	4
3.2. OPERATING Principle	4
3.3. PRODUCTS THAT MUST BE AVOIDED.....	4
3.4. APPLICATION	4
4. Installation	
4.1. RECEPTION.....	5
4.2. TRANSPORT AND STORAGE.....	5
4.3. LOCATION	5
4.4. PIPING	6
4.5. SHUT-OFF VALVES.....	6
4.6. Electrical installation.....	7
5. Start-up	
5.1. Start-up	8
6. Operating Problems	
7. Maintenance	
7.1. GENERAL POINTS	10
7.2. STORAGE.....	10
7.3. CLEANING.....	10
7.4. DISASSEMBLY / ASSEMBLY OF THE mixer.....	11
8. Technical Specifications	
8.1. Technical Specifications.....	12

3. General Information

3.1. DESCRIPTION

For series M-226 Ex mixers, the motors should be appropriate to operate in explosive atmospheres. Pneumatic butterfly valve.

The Atex mixer suction may optionally be provided with flow meter as a flow sensor, and also a solids sensor in the bottom of the hopper with another one possible at the top. The hopper may also be fitted with a vibrator.

The butterfly valve may be Atex manual.

All of the above additional complement must be adapted to work in explosive atmospheres.

3.2. OPERATING PRINCIPLE



This symbol shall accompany the safety instructions of this annex. Said instructions are related to the risk of forming explosive atmospheres or creating sources of fire in hazardous environments. Please comply with these instructions to avoid putting your life in danger.

The mixer has been selected for certain pumping and working conditions

3.3. PRODUCTS THAT MUST BE AVOIDED

Not applicable in this ATEX Annex.

3.4. APPLICATION

The mixer has been selected according to very specific pumping conditions, and working conditions in explosive atmospheres. The various options were chosen at the time of ordering. INOXPA shall not be held liable for damages that may result from incomplete or incorrect information provided by the purchaser (e.g. nature of the liquid, rpm, potential explosive-risk area classification, and gases given off under the effect of this potentially explosive atmosphere)

The motors that must be used must have an EC mark under ATEX directive 2014/34/EU and the manufacturer's corresponding instructions and national and local regulations

This equipment must comply with regulations in force, particularly local regulations, decrees, provisions, laws, directives, application circulars, regulations, labour regulations, and any other document related with the place where it is fitted

4. Installation

4.1. RECEPTION

Check that the received mixer is adapted to the working conditions in the classified area according to the conditions provided at the time the order was made

4.1.1. Mixer identification

The received package must be checked by following the instructions set out in this manual. The EC ATEX mark of the equipment must also be checked. This mark must be inscribed on the manufacturer's plate. Remember, this mark must also comply with the requirements of the order.

The marking on the nameplate refers to the mixer unit (motor + hydraulic).

In the event that it is supplied without a motor, the marking will refer only to the mixer (hydraulic). In this case, it will be the end user who must ensure that the motor to be assembled is suitable for working in the appropriate explosive zone (according to the marking on the characteristics plate). The indications in the motor instruction manual must be followed when mounting the mixer unit.

The nameplate can have different markings:

 II 2G Ex h IIB T4...T3 Gb
II 2D Ex h IIIB T125 °C...T140 °C

 II 2G Ex h IIB T4...T3 Gb

 II 2D Ex h IIIB T125 °C...T140 °C

EC ATEX mark inscribed on the manufacturer's plate.

The temperature class and the maximum surface temperature depend on the temperature of the product to be pumped and the ambient temperature.

Temperature class for explosive gas atmospheres

Temperature class	Product temperature (in process or cleaning)	Room temperature
T4	≤ 110 °C	-20 °C to +40 °C
T3	≤ 140 °C	-20 °C to +40 °C

Maximum surface temperature for explosive dust atmospheres

Maximum surface temperature	Product temperature (in process or cleaning)	Room temperature
T 125 °C	≤ 125 °C	-20 °C to +40 °C
T 140 °C	≤ 140 °C	-20 °C to +40 °C

4.2. TRANSPORT AND STORAGE

If the mixer is not going to be used immediately, its position must be changed twice a week to ensure that the impeller, mechanical seals, etc. do not seize up.

4.3. LOCATION

Place the mixer near a drain in the floor. Remember, if you are operating with flammable liquid, an area classified for flows, such as area 0, may be generated. You must therefore comply with the applicable safety instructions.

The motors used must have an EC mark under ATEX directive 2014/34/EU and the manufacturer's corresponding instructions and national and local regulations.

If pumping flammable or explosive liquids, use an appropriate connection. Connect the parts of the assembly with the earth connection points in order to reduce the risk of static electricity

The temperatures inside and outside the mixer may increase considerably according to the fluid being pumped.

Remember, the surface temperature of the mixer is determined by the normal temperature conditions of the fluid being pumped, so the table of temperature classes and maximum surface temperature in section 4.1.1

It is necessary to provide air circulation for the mixer motor to cool. Ensure that there is no other equipment or surfaces close to the motor which might radiate additional heat or affect the motor's cooling. Consult the motor's instructions manual

4.4. PIPING

Pay attention to thermal dilation when hot liquids are being pumped. In this case, use expansion washers and ensure that the equipment is not left electrically isolated (electric equipotentiality) from the rest of the assembly.

Before starting up the mixer, check that the mixer's suction and discharge pipe valves are open

Ensure that the mixer has been properly stopped before closing these two valve

If a filter is fitted onto the suction pipe, it must comply with Directive 2014/34/EU ATEX

If a filter is fitted onto the suction pipe, it must comply with Directive 2014/34/EU ATEX. A periodic inspection must be carried out so that the filters do not become blocked up, as this could lead to the mixer running dry

If the relevant option has been selected, ensure that the flow meter has been connected (see supplier's manual) to the diffuser suction piping, as this provides information on whether the liquids are moving or not. This will ensure that the mixer housing is primed (full). Afterwards, there is no possibility of air getting inside the housing, thus eliminating explosion-risk area

If the relevant option has been selected, ensure that the solid level sensors have been connected (see supplier's manual) as this ensures that air goes into the diffuser, thus eliminating the explosion risk

In the case of the manual option, connect the butterfly valve according to the manufacturer's instructions manual

If the relevant option has been selected, connect the vibrator according to the supplier's instructions manual

4.5. SHUT-OFF VALVES

Use valves with an EC mark under ATEX directive 2014/34/EU and the manufacturer's corresponding instructions and national and local regulations

4.6. ELECTRICAL INSTALLATION

Before connecting an electric motor to the electrical point, check local regulations regarding electric safety, as well as standards EN 60204-1 and EN 60079-14 current at the moment.

Always follow the motor manufacturer's instructions

Automatic circuit-breaker

Take into account that these circuit-breakers may have to work in a potentially explosive environment. Therefore, CE Atex-registered circuit-breakers must be chosen in accordance with Directive 2014/34/EU as necessary.

The handling equipment must comply with the regulations in force according to electrical safety rules, as well as indications stipulated by the Atex motor manufacturer

Connection

Consult the supplier's instructions manual before connecting the motor to the electric point. This motor should be ATEX with adequate protection for the work environment in which it operates.

The electrical equipment, terminals and components of the control systems may still contain electric current when switched off. Contact with them may be dangerous for operators and installation or cause irreversible damage to the equipment. The supplier's instructions must be observed in order to open the motor in complete safety

Safe work permits must be issued in order to handle the equipment in potentially explosive atmospheres, and it is advisable to carry this type of work in unclassified atmospheres (in the mixer location, there shall be no explosive atmosphere during handling)

The rotating direction must be controlled with the motor uncoupled from the mixer

In addition, install motor overload protection, adapted to the rated power of the motor

5. Start-up

Before starting up, those responsible must be properly informed about the mixer and the safety instructions. This Annex, along with the instruction manual, will at all times be at the personnel's disposal

Special safety measures such as work permits, etc. must be issued in order to carry out any kind of work in potentially explosive atmospheres

5.1. START-UP

Starting up the mixer may create an explosive atmosphere. It is therefore necessary to issue safe work permits. Additionally, the tasks must only be carried out by staff qualified and trained for this purpose

5.1.1. Checks before starting up the mixer

Ensure that the hopper valve is shut

Before starting up the mixer, check that the mixer suction and discharge valves are open

In the case of the (non-flushed) single seal option, the mixer and the area around the lock must be covered by the pump fluid before start up.

If a flow meter has not been selected, the client must install a flow detection sensor in the mixer suction nozzle or any other safety device to prevent the mixer from running dry.

If the liquid to be pumped is flammable, the possibility of potentially explosive atmospheres forming must be considered, and if this is the case, issue safe work permits

5.1.2. Checks when starting up the mixer

Not applicable in this ATEX Annex.

6. Operating Problems

Not applicable in this ATEX Annex.

7. Maintenance

7.1. GENERAL POINTS

The maintenance work on any equipment intended for use in potentially explosive atmospheres requires that safe work permits be issued as specified by EU Directive 1999/92/EC

Maintenance work may only be carried out by qualified staff. Use proper clothing. Ensure that the staff have read the instructions manual in full, as well as this annex, especially the chapters related to the work to be carried out

Environment

The working environment should be clean. Some parts are very fragile and others have low tolerance levels.

Furthermore, the possibility of explosive atmospheres must not be forgotten. Safe work permits must therefore be issued.

Tools

Use technically appropriate tools for maintenance and repair work. If the area is not sealed off, all tools must be explosion-proof, and safe work permits must be issued.

Safety

In addition to the instructions included in the manual, the instructions of the motor's manufacturer must also be followed strictly in order to open the motor safely.

7.1.1. Checking the mechanical seal

Consult the supplier's instructions manual.

7.2. STORAGE

Not applicable in this ATEX Annex.

7.3. CLEANING

The user is responsible for establishing a cleaning and disinfection schedule appropriate for their needs. This schedule shall take into account all applicable laws, regulations and standards relating to public health protection and safety of use, as well as chemical products treatment.

Be aware that explosive atmospheres may exist or be formed when emptying the mixer. It is therefore necessary to issue safe work permits and eliminate the possibility of ignition sources near the equipment or workplace

Start-up may create a potentially explosive atmosphere. Safe work permits must therefore be issued. Additionally, only qualified and duly trained staff may intervene

External cleaning

Do not spray the hot parts of the mixer with water, as some components may crack and the pump fluid may spill into the environment and create an explosive atmosphere

An external clean of the equipment should be carried out to prevent the excessive accumulation of combustible or explosive powder on the outside surface of the equipment. Accumulations of a thickness greater than 2 mm must never be permitted

Paintwork

If the appearance of rust on the painted surface of the equipment is observed, this area must be repainted to prevent any type of anomaly from occurring. The material is made of is an alloy containing less than 7.5% of light metals.

A painted surface with a thickness greater than 5 mm must never be permitted.

Spare parts

If you order spare parts for a mixer intended for operation in a classified area, you must explicitly indicate in the order that they are for an Atex mixer and state the manufacturing number. Otherwise, INOXPA shall not be liable if the mixer is operated with parts not appropriate for the classified area where it is installed.

7.3.1. CIP (Clean-in-place)

Not applicable in this ATEX Annex.

7.4. DISASSEMBLY / ASSEMBLY OF THE MIXER.

Incorrect assembly or disassembly may cause damage to the mixer operation thus leading to considerable repair costs, long periods of downtime, and may even negate the effect of the equipment's protection systems

INOXPA shall not be liable for accidents or damage caused as a result of the non-fulfilment of the instruction manual and this Annex

Preparation

In addition to the indications set out in this manual, the possibility of explosive atmospheres must be considered and safe work permits must therefore be issued.

Tools

Use technically-appropriate tools for maintenance and repair work. If the area is not definitively sealed off, all the tools should be explosion-proof and safe work permits should be issued.

Cleaning

Before starting disassembly of the mixer, it must be cleaned, inside and outside. Furthermore, the possibility of explosive atmospheres must not be forgotten. Safe work permits must therefore be issued.

Electrical safety

In addition to the instructions included in the manual, the instructions of the motor's manufacturer must also be followed strictly in order to open the motor safely.

The possibility of explosive atmospheres existing or being formed must not be neglected. It is therefore necessary to issue safe work permits and eliminate any ignition sources near the equipment

Be aware that explosive atmospheres may exist or be formed when emptying the pump. It is therefore necessary to issue safe work permits and eliminate the possibility of ignition sources near the equipment or workplace

Casing and impeller



Caution! Liquid may spill from the casing when lifting the mixer cover, which may cause a potentially explosive atmosphere.

8. Technical Specifications

8.1. TECHNICAL SPECIFICATIONS

Temperature range. See section 4.1.1.

Single mechanical seal

If the single mechanical seal runs dry, the maximum temperature in the operating area may be exceeded. This is why a single mechanical seal must not run dry under any circumstances in dry conditions.

If a flow meter has not been selected, the client must fit a flow detection sensor in the mixer suction nozzle or any other safety device to prevent the mixer from running dry.

Consult the supplier's instructions manual for maintenance.

Flushed mechanical seal

Consult the supplier's instructions manual for maintenance.

Frequent contamination leads to an unacceptable leak in the watertight system and must therefore be repaired.

Flow meter, vibrometer, and solids detector

Consult the supplier's instructions manual.

Materials

For the maximum temperature of the gaskets: consult the maximum temperature values table.